

2014

# Investigation of soil stabilization using biopolymers

Liuhui Guo  
*Iowa State University*

Follow this and additional works at: <https://lib.dr.iastate.edu/etd>

 Part of the [Chemical Engineering Commons](#), [Civil Engineering Commons](#), and the [Mechanics of Materials Commons](#)

## Recommended Citation

Guo, Liuhui, "Investigation of soil stabilization using biopolymers" (2014). *Graduate Theses and Dissertations*. 13909.  
<https://lib.dr.iastate.edu/etd/13909>

This Thesis is brought to you for free and open access by the Iowa State University Capstones, Theses and Dissertations at Iowa State University Digital Repository. It has been accepted for inclusion in Graduate Theses and Dissertations by an authorized administrator of Iowa State University Digital Repository. For more information, please contact [digirep@iastate.edu](mailto:digirep@iastate.edu).

# **Investigation of soil stabilization using biopolymers**

by

**Liuhui Guo**

A thesis submitted to the graduate faculty  
in partial fulfillment of the requirements for the degree of  
**MASTER OF SCIENCE**

Major: Civil Engineering (Geotechnical Engineering)

Program of Study Committee:  
Jeremy C. Ashlock, Major Professor  
R. Christopher Williams  
Eric W. Cochran

Iowa State University  
Ames, Iowa  
2014

Copyright © Liuhui Guo, 2014. All rights reserved.

## TABLE OF CONTENTS

LIST OF TABLES .....	iv
LIST OF FIGURES .....	v
ACKNOWLEDGMENTS .....	ix
ABSTRACT.....	x
CHAPTER 1. INTRODUCTION .....	1
CHAPTER 2. LITERATURE REVIEW .....	3
Compaction of Geomaterials .....	3
Compaction for cohesive soils .....	7
Compaction for cohesionless soils .....	8
Methods of soil stabilization.....	9
Traditional stabilization .....	11
Cement .....	11
Lime .....	14
Fly ash .....	14
Bitumen .....	14
Nontraditional stabilization.....	15
Polymers.....	15
Microbial stabilization.....	22
Shear strength of soil .....	23
Mohr-Coulomb Failure criterion.....	23
Unconfined compressive strength.....	25
Direct shear test.....	26
CHAPTER 3. MATERIALS AND METHODS .....	29
Test Materials.....	29
Western Iowa loess (Silt) .....	29
Ottawa sand (ASTM 20-30 sand) .....	31
Monomers .....	33
Biopolymers .....	33
Cement .....	34
Test Methods.....	34
Specimen preparation.....	34
Western Iowa Loess .....	35
Ottawa (ASTM 20-30) sand .....	35
Compaction test.....	38
Western Iowa Loess .....	39
Ottawa sand (ASTM 20-30 sand).....	40
Evaluation of strength .....	41
Unconfined compression test (Loess) .....	41

Direct shear test (Ottawa sand) .....	43
CHAPTER 4. EXPERIMENTAL RESULTS AND DISCUSSION .....	48
Western Iowa Loess .....	48
Compaction test results .....	48
Unconfined compressive strength results.....	49
Effect of curing time and monomer content on UCS .....	50
Effect of monomer content on UCS of loess specimens .....	53
Effect of polymer content on stress-strain behavior.....	53
Ottawa sand.....	57
Compaction test results .....	58
Direct shear test results .....	59
Shear stress and volume change behavior in direct shear tests .....	62
Drained Mohr-Coulomb shear strength parameters from direct shear tests.....	80
Effect of polymer aging on shear stress .....	86
Healing property of polymer-amended specimens.....	87
Effect of water on polymer-amended specimens .....	91
CHAPTER 5. CONCLUSIONS AND RECOMMENDATIONS .....	92
Conclusions.....	92
Unconfined compression test results for loess .....	92
Direct shear test results for Ottawa sand.....	93
Summary .....	94
Recommendations for further research.....	95
Works Cited .....	97

## LIST OF TABLES

Table 1. Specifications for the Two Proctor Laboratory Compaction Tests. ....	6
Table 2. Unconfined compression test results and density measurements for CH Test Series (from Tingle and Stanton, 2003). ....	18
Table 3. Unconfined compression test results and density measurements for CL Test Series (from Tingle and Stanton, 2003). ....	19
Table 4. Typical values of drained angle of friction for sands and silts (from Das, 2010). ....	24
Table 5. Triaxial test results for some normally consolidated clays obtained by the Norwegian Geotechnical institute (from Das 2010). ....	25
Table 6. Typical properties of Ottawa 20-30 sand (from Santamarina et al., 2001). ....	32
Table 7. Actual measured dimensions, total mass, and bulk unit weight for the polymer-amended specimens after curing. ....	46
Table 8. Dimensions of cured polymer-amended specimens, and estimated dry unit weight, void ratio, and relative density of the sand fraction. ....	47
Table 9. Unconfined compressive strength results for monomer-treated loess specimens. ....	51
Table 10. Summary of shear strength parameters from direct shear tests on Ottawa 20/30 sand specimens. ....	81

## LIST OF FIGURES

Figure 1. Hogentogler's explanation of the compaction curve (from Hilf, 1991).....	4
Figure 2. Compaction curve in terms of void ratio vs. water void ratio and dry density vs. moisture content for $GS = 2.60$ (from Hilf, 1991). .....	5
Figure 3. Average maximum densities of soil-cement mixtures not containing material retained on the No. 4 sieve (from PCA, 1956).....	12
Figure 4. Cement content to use in soil-cement mixtures not containing material retained on the No.4 sieve (from PCA, 1956). .....	13
Figure 5. Minimum 7-day compressive strength required for soil-cement mixtures not containing material retained on the No.4 sieve (from PCA, 1956).....	13
Figure 6. Schematic depiction of (a) anionic PAM; (b) charged cellulose microfibrils interacting with charged soil particles in the presence of calcium.....	16
Figure 7. Mohr-Coulomb failure criterion (from Craig, 2005).....	24
Figure 8. Unconfined compression test (from Das, 2010).....	26
Figure 9. Direct shear apparatus and measured forces and displacements .....	27
Figure 10. Typical direct shear test results for dense sand; (a) shear stress and height change versus shearing displacement for specimens at the same initial relative density; (b) Mohr-Coulomb failure envelope (from Holtz et al., 2011). .....	27
Figure 11. Typical direct shear test results for dense sand with different initial void ratios (loose vs. dense) and same vertical stress (a): shear stress and volume change vs. shear displacement, (b): void ratio vs. shear displacement (from Das, 2010).....	28
Figure 12. Outline of major loess deposits in the United States (from Gibbs et al., 1960). ....	30
Figure 13. Particle size distribution curve of western Iowa loess (from Li, 2013).....	31
Figure 14. Particle size distribution curve of Ottawa sand (from Li, 2013). .....	32
Figure 15. Hot-plate and magnetic stirrer apparatus for mixing glycerol monomers/polymers with water. ....	36
Figure 16. Preparation method for the polymer-stabilized sand specimens. ....	37
Figure 17. Preparation method for the cement-stabilized sand specimens. ....	38
Figure 18. ISU 2×2 compaction device: (a) photo, and (b) schematic .....	39
Figure 19. Geotac automated equipment used for unconfined compression tests. ....	42
Figure 20. Geotac automated direct shear test device.....	43
Figure 21. Compaction test results for untreated loess. ....	48
Figure 22. Typical failure of monomer-treated specimens in unconfined compression tests.....	49

Figure 23. Typical failure of untreated specimens in unconfined compression tests. ....	50
Figure 24. Effect of curing time up to 7 days on average UCS of untreated and monomer-amended loess specimens.....	52
Figure 25. Effect of curing time up to 28 days on average UCS of untreated and monomer-amended loess specimens.....	52
Figure 26. Effect of monomer content and curing time on average UCS of loess specimens compacted at OMC.....	53
Figure 27. Effect of monomer content on UC stress-strain response of loess for curing time of 1 hour.....	55
Figure 28. Effect of monomer content on UC stress-strain response of loess for curing time of 1 day.....	55
Figure 29. Effect of monomer content on UC stress-strain response of loess for curing time of 7 days.....	56
Figure 30. Effect of monomer content on UC stress-strain response of loess for curing time of 28 days.....	56
Figure 31. Compaction test results for Ottawa sand.....	59
Figure 32. 8% cement-amended sand specimen after failure.....	60
Figure 33. 2% polymer-amended sand specimen after failure.....	61
Figure 34. 4% polymer-amended sand specimen after failure.....	61
Figure 35. Shear stress versus horizontal displacement for untreated Ottawa 20/30 sand.....	63
Figure 36. Vertical displacement versus horizontal displacement for untreated Ottawa 20/30 sand.....	63
Figure 37. Shear stress versus horizontal displacement for cement-amended sand.....	64
Figure 38. Vertical displacement versus horizontal displacement for cement-amended sand.....	64
Figure 39. Shear stress versus horizontal displacement for G54 polymer-amended sand.....	65
Figure 40. Vertical displacement versus horizontal displacement for G54 polymer-amended sand.....	65
Figure 41. Shear stress versus horizontal displacement for G101 polymer-amended sand.....	66
Figure 42. Vertical displacement versus horizontal displacement for G101 polymer-amended sand.....	66
Figure 43. Shear stress versus horizontal displacement for Batch 2 G54 polymer-amended sand.....	67
Figure 44. Vertical displacement versus horizontal displacement for Batch 2 G54 polymer-amended sand.....	67
Figure 45. Shear stress versus horizontal displacement for cement-amended sand.....	68

Figure 46. Vertical displacement versus horizontal displacement for cement-amended sand (Normal stress = 10 psi).....	68
Figure 47. Shear stress versus horizontal displacement for cement-amended sand .....	69
Figure 48. Vertical displacement versus horizontal displacement for cement-amended sand (Normal stress = 20 psi).....	69
Figure 49. Shear stress versus horizontal displacement for cement-amended sand .....	70
Figure 50. Vertical displacement versus horizontal displacement for cement-amended sand (Normal stress = 30 psi).....	70
Figure 51. Shear stress versus horizontal displacement for G54 polymer-amended sand.....	71
Figure 52. Vertical displacement versus horizontal displacement for G54 polymer-amended sand (Normal stress = 10 psi). .....	71
Figure 53. Shear stress versus horizontal displacement for G54 polymer-amended sand.....	72
Figure 54. Vertical displacement versus horizontal displacement for G54 polymer-amended sand (Normal stress = 20 psi). .....	72
Figure 55. Shear stress versus horizontal displacement for G54 polymer-amended sand.....	73
Figure 56. Vertical displacement versus horizontal displacement for G54 polymer-amended sand (Normal stress = 30 psi). .....	73
Figure 57. Shear stress versus horizontal displacement for Batch 2 G54 polymer-amended sand (Normal stress = 10 psi). .....	74
Figure 58. Vertical displacement versus horizontal displacement for Batch G54 polymer-amended sand (Normal stress = 10 psi). .....	74
Figure 59. Shear stress versus horizontal displacement for Batch 2 G54 polymer-amended sand (Normal stress = 20 psi). .....	75
Figure 60. Vertical displacement versus horizontal displacement for Batch G54 polymer-amended sand (Normal stress = 20 psi). .....	75
Figure 61. Shear stress versus horizontal displacement for Batch 2 G54 polymer-amended sand (Normal stress = 30 psi). .....	76
Figure 62. Vertical displacement versus horizontal displacement for Batch G54 polymer-amended sand (Normal stress = 30 psi). .....	76
Figure 63. Shear stress versus horizontal displacement for G101 polymer-amended sand (Normal stress = 10 psi). .....	77
Figure 64. Vertical displacement versus horizontal displacement for G101 polymer-amended sand. (Normal stress = 10 psi). .....	77
Figure 65. Shear stress versus horizontal displacement for G101 polymer-amended sand (Normal stress = 20 psi). .....	78



Figure 66. Vertical displacement versus horizontal displacement for G101 polymer-amended sand (Normal stress = 20 psi). .....	78
Figure 67. Shear stress versus horizontal displacement for G101 polymer-amended sand (Normal stress = 30 psi). .....	79
Figure 68. Vertical displacement versus horizontal displacement for G101 polymer-amended sand (Normal stress = 30 psi). .....	79
Figure 69. Shear strength versus effective normal stress and Mohr-Coulomb failure envelopes for G54 polymer. ....	82
Figure 70. Shear strength versus effective normal stress and Mohr-Coulomb failure envelopes for G101 polymer. ....	83
Figure 71. Shear strength versus effective normal stress and Mohr-Coulomb failure envelopes for batch 2 G54 polymer. ....	84
Figure 72. Relationship between friction angle and polymer content. ....	85
Figure 73. Relationship between cohesion and polymer content. ....	85
Figure 74. Relationship between shear strength and age of the polymer from date of Trial 1. ....	87
Figure 75. Healed 4% polymer-amended sand specimen 7 days after first DS test. ....	88
Figure 76. Shear stress versus horizontal displacement for untreated sand, initial test on polymer-treated sand, and retest after 7 days healing (Normal stress = 10 psi). ....	89
Figure 77. Vertical displacement versus horizontal displacement for untreated sand, initial test on polymer-treated sand, and retest after 7 days healing .....	89
Figure 78. Shear stress versus horizontal displacement for untreated sand, initial test on polymer-treated sand, and retest after 7 days healing (Normal stress = 20 psi). ....	90
Figure 79. Vertical displacement versus horizontal displacement for untreated sand, initial test on polymer-treated sand, and retest after 7 days healing .....	90
Figure 80. Submerged polymer-amended specimens. The specimen on the left was gently probed with a spatula. ....	91

## ACKNOWLEDGMENTS

Foremost, I would like to thank my major professor, Dr. Jeramy Ashlock, for his patience, motivation, enthusiasm, and immense help throughout my graduate studies.

I would also like to thank Dr. R. Christopher Williams and Dr. Eric Cochran for severing on my committee.

A special thanks to my parents, Jinping Guo and Qiumin Liu, for their support and understanding. Thanks for the encouragement from all of my friends, especially for Zhimin Li and Luyi Wang.

## ABSTRACT

This study evaluated the shear strength behavior of bio-stabilized soils over a range of amended bio-monomer and biopolymer soil addition rates using Western Iowa loess and Ottawa 20/30 sand. The unconfined compressive strength and ductility of loess was characterized after adding 2% to 4% monomer. For Ottawa sand, the shear strength and volume-change behavior of specimens stabilized by three different biopolymers at concentrations of 1%, 2% and 4% was tested. All specimens were prepared at moisture contents of optimum or 2% dry of optimum. To determine the optimum moisture content of the loess material, a modified 2"×4" compaction test was conducted to satisfy the specimen aspect ratio requirement.

The unconfined compressive strength of monomer-amended loess was decreased significantly within the first 7 days of curing, but increased compared to untreated soil over 28 days of curing time. Based on these results, the monomer shows some potential for providing strength and ductility benefits for loess after curing times of 28 days or more.

For the Ottawa 20/30 sand, the peak strength of polymer-amended specimens for a given normal stress was increased by 1.5 to 2 times that of untreated sand. The G54 polymer gave the best results with a peak shear strength 1.4 to 1.5 times that of the 8% cement-amended sand, but this was lower than the strength using 12% cement. However, the values of cohesion imparted by all three polymers were comparable to those resulting from 8% and 12% cement. The failure behavior of the sand was made more ductile by the polymer, and beneficial effects of polymer aging and healing abilities were discovered.

The strength of the cohesionless sand improved significantly in all polymer-amended specimens. The improved results from the G54 biopolymer compared to those from cement demonstrate the potential of biopolymer as a substitute for traditional stabilizers.

## CHAPTER 1. INTRODUCTION

In recent years, nontraditional stabilization methods using materials such as salts, acids, enzymes, lignosulfonates, petroleum emulsions, polymers, and tree resins have been studied to seek substitutes for traditional stabilization materials such as cement, fly ash, and lime in both commercial and military applications. A number of studies have also been aimed at bio-stabilization of sands for liquefaction mitigation, using urea produced by bacteria cultures to provide cementation, or bio-desaturation using nitrogen gas bubbles to reduce the degree of saturation. Using such nontraditional stabilization materials, additive amounts and curing times can potentially be decreased and strength increased over those of traditional methods. The environmental impact from chemical reactions produced by traditional stabilization methods might also possibly be decreased using such nontraditional methods.

Polymer, either natural or synthetic, is one of the nontraditional stabilizer types of increasing interest. Past studies have described the application of natural polymers to stabilize low-volume road surfaces, and synthetic polymer has also been used to increase the strength and decrease the hydraulic conductivity of sand.

Although a few studies in recent years have examined nontraditional stabilization, there are still no standards for selecting the appropriate types and amounts of nontraditional stabilizers for various soil types and engineering applications. Determining the engineering properties of polymer-modified soils requires extensive laboratory testing, and the optimum concentrations of polymer and preparation methods such as curing time and temperature have not yet been fully understood.

The goal of this research is to evaluate the strength behavior of soil amended with newly-developed biological monomers and polymers, and to determine the effect of the bio-

stabilizers on engineering properties of both cohesive and cohesionless soils. Shear strength of biopolymer-amended loess and sand specimens were measured in unconfined compression tests and direct shear tests. Specimens with varied monomer or polymer content were prepared at optimum moisture content as determined by compaction testing, and tested to determine the optimum monomer or polymer content to be added to the soil.

A literature review of compaction theory and traditional and nontraditional stabilization methodology is presented in Chapter 2 to provide background for this research. Test methods and materials are described in Chapter 3. Test results and discussion regarding soil shear strength behavior are given in Chapter 4. Finally, conclusions and recommendations for future research are summarized in Chapter 5.

## CHAPTER 2. LITERATURE REVIEW

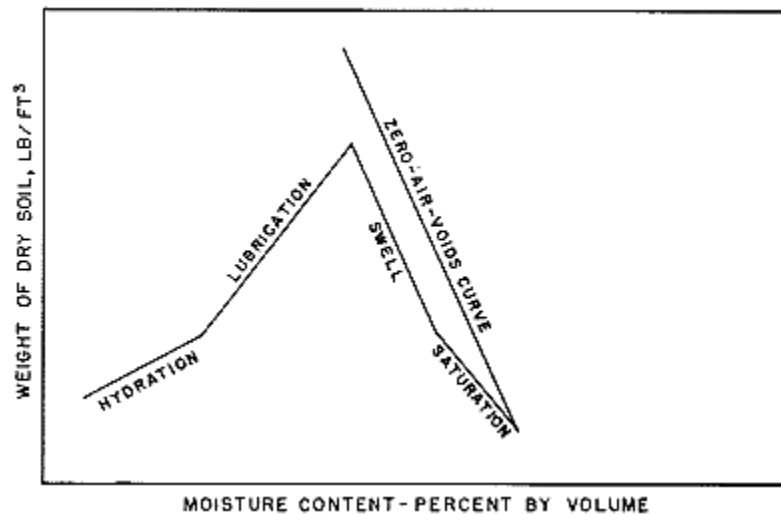
This chapter provides a review of existing literature on the subjects of compaction, stabilization, and shear strength of soils as evaluated by the unconfined compression and direct shear tests.

### Compaction of Geomaterials

Compaction is the process of reducing the volume of soil by application of loads such as impacts, rolling, tamping, or vibration. During compaction, air is expelled and the moisture content is slightly changed. Additionally, the engineering properties of soil are also affected; the shear strength of soil generally increases while compressibility and permeability typically decrease. Compacted well-graded gravel may be up to 15 times as resistant to deformation under a bearing load as the same material in a loose state. Different laboratory and field compaction test methods may use for soils classified as cohesive or cohesionless according to the AASHTO classification system and USCS (Unified Soil Classification System). In the past century, much research has focused on compaction theory and test methods. A brief discussion of these studies is given below.

Compaction curves for cohesive soil have been explained by several theoretical viewpoints, as the physical process of compaction is somewhat complex. Based on research from Proctor (1933), Hogentogler (1936), Hilf (1956), Lambe (1960), Barden and Sides (1970), and Olson (1963), the compaction process is affected by capillary pressure, hysteresis, pore air pressure, pore water pressure, permeability, surface phenomena, osmotic pressures, effective stress, shear strength, and compressibility (Hilf 1991). Proctor (1933) suggested that capillary effects that hold particles together as a result of moisture in partially-saturated soil play a key role, and that maximum density for a given compactive effort occurs when there is

sufficient water and a small amount of air to fill the voids. Hogentogler (1936) defined four stages to characterize the compaction curve: hydration, lubrication, swelling, and saturation (Figure 1). Theoretically, the optimum moisture content occurs when maximum density is reached during the lubrication process, at which point all the air is removed and soil is saturated. In this case, the compaction curve would intersect with the zero-air-voids (ZAV) curve. However, it is generally not possible to reach 100% saturation by mechanical compaction, so compaction curves typically lie below the ZAV curve. It is well-known that the compaction curve on the wet side of optimum tends to be parallel to the zero-air-voids curve.

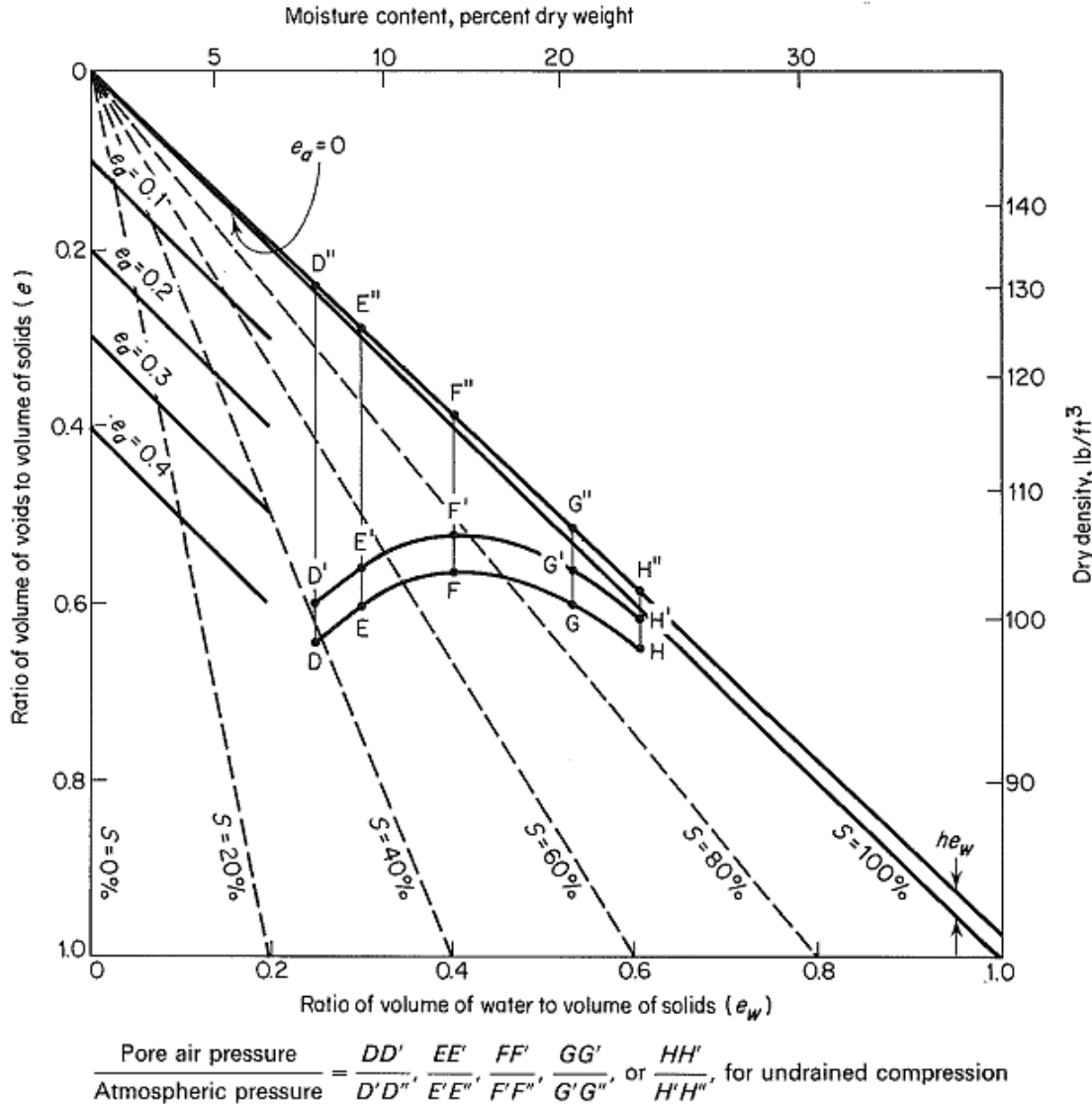


**Figure 1. Hogentogler's explanation of the compaction curve (from Hilf, 1991).**

Hilf (1956) explained the process of compaction and the resulting moisture-density relationship using the theory of pore water pressures in unsaturated soils. The void ratio versus water void ratio (defined as volume of water per unit volume of solids) graph from his explanation is shown in Figure 2 as a substitute for the compaction curve from the Proctor test. Other methods for explaining the shape of the compaction curve include the surface



chemical theory introduced by Lambe (1960) and the effective stress concept presented by Olson (1963).



**Figure 2. Compaction curve in terms of void ratio vs. water void ratio and dry density vs. moisture content for  $GS = 2.60$  (from Hilf, 1991).**

To determine the compaction curve, Proctor (1933) showed that there is a relationship between the maximum density, moisture content, and compaction energy imparted to the soil during the compaction process. Proctor then developed a laboratory test to determine the optimum moisture content and maximum density. The laboratory compaction test was

designed to deliver a compaction energy per unit volume equivalent to the field compaction energy of 12 passes of a 20-ton dual-drum sheepsfoot roller on 8 to 9 inch loose layers of cohesive soils. Standard laboratory procedures, equipment, and methods for reporting results were developed and accepted as American Society for Testing and Materials (ASTM) Standard D698 and American Association of State Transportation and Highway Officials (AASHTO) T 99. Subsequently, a modified test procedure to simulate the use of heavier compaction equipment was developed as ASTM D1558 and AASHTO D180 (Hilf, 1991). The specifications for the two Proctor compaction tests are shown in Table 1.

**Table 1. Specifications for the Two Proctor Laboratory Compaction Tests.**

Test	Standard Effort(ASTM Test Method D 698)			Modified Effort(ASTM Test Method D 1557)		
	A	B	C	A	B	C
Method						
Rammer weight	5.5 lbf (24.4 N)	5.5 lbf (24.4 N)	5.5 lbf (24.4 N)	10 lbf (44.5 N)	10 lbf (44.5 N)	10 lbf (44.5 N)
Height of drop	12 in. (305 mm)	12 in. (305 mm)	12 in. (305 mm)	18 in. (457 mm)	18 in. (457 mm)	18 in. (457 mm)
Mold diameter	4 in. (102 mm)	4 in. (102 mm)	6 in. (152 mm)	4 in. (102 mm)	4 in. (102 mm)	6 in. (152 mm)
Mold	0.0333 ft <sup>3</sup> (944 cm <sup>3</sup> )	0.0333 ft <sup>3</sup> (944 cm <sup>3</sup> )	0.075 ft <sup>3</sup> (2124 cm <sup>3</sup> )	0.0333 ft <sup>3</sup> (944 cm <sup>3</sup> )	0.0333 ft <sup>3</sup> (944 cm <sup>3</sup> )	0.075 ft <sup>3</sup> (2124 cm <sup>3</sup> )
Material	Passing No.4 (4.75mm) sieve	Passing 3/8 in. (9.5 mm) sieve	Passing 3/4 in. (19 mm) sieve	Passing No.4 (4.75mm) sieve	Passing 3/8 in. (9.5 mm) sieve	Passing 3/4 in. (19 mm) sieve
Layers	3	3	3	5	5	5
Blows per layer	25	25	56	25	25	56
Compactive effort	12 400 ft-lbf/ft <sup>3</sup> (600 kN-m/m <sup>3</sup> )	12 400 ft-lbf/ft <sup>3</sup> (600 kN-m/m <sup>3</sup> )	12 400 ft-lbf/ft <sup>3</sup> (600 kN-m/m <sup>3</sup> )	56 000 ft-lbf/ft <sup>3</sup> (2700 kN-m/m <sup>3</sup> )	56 000 ft-lbf/ft <sup>3</sup> (2700 kN-m/m <sup>3</sup> )	56 000 ft-lbf/ft <sup>3</sup> (2700 kN-m/m <sup>3</sup> )
Use	≤25% by mass retained on No.4 sieve	≤25% by weight retained on 9.5 mm sieve	≤30% by weight retained on 19 mm sieve	≤25% by mass retained on No.4 sieve	≤25% by weight retained on 9.5 mm sieve	≤30% by weight retained on 19 mm sieve

In addition to the well-known standard and modified Proctor compaction tests, other moisture-density tests were developed to save both soil and time during compaction testing. British engineers in the late 1940's developed the Dietert test (Great Britain, 1952). The Dietert apparatus was more convenient than that used in the Proctor test, but had the disadvantages of a cumbersome apparatus, and compacted specimens that were not of the

same size. The procedure also resulted in specimen densities that were higher than those of the standard Proctor test. Later, in 1950, the Harvard test using a 1.3125 inch diameter and 2.816 inch height cylindrical mold was developed. The compaction energies and procedures of this test, however, were not the same as for field compaction nor Proctor tests, and the correlation between the Proctor and Harvard tests was studied by Wilson (1950).

Finally, Davidson and Chu (1966) developed the Iowa compaction test, which featured an easily-constructed apparatus, reduced preparation and compaction times, and good reproducibility of results. Unlike the Proctor compaction test, the compaction energy could be varied from soil to soil. The Iowa 2×2 compaction test produced results within field and laboratory attainable accuracies, and the maximum density and optimum moisture content obtained from this test were the same as those from the standard Proctor test. (Oflaherty, et al., 1963).

Four variables: dry density (or dry unit weight), water content, compaction effort, and soil type (gradation, presence of clay minerals, etc.) were noted in the Proctor compaction test. The mechanical energy applied per unit volume of the soil mass is termed the compaction effort, and is calculated from the product of the mass of the rammer, height of drop, number of drops per layer, and number of layers of soil, divided by the volume of the mold (Holtz et al., 2011).

### **Compaction for cohesive soils**

A cohesive soil is one with a high silt or clay content that has cohesive strength due to cementitious bonds or electrostatic forces between particles. Partially saturated non-plastic soils can also exhibit apparent cohesion due to negative capillary pressure which may be lost upon wetting. Saturated or partially saturated non-plastic soils may also exhibit apparent

cohesion due to temporary negative pore pressures caused by dilation during shearing. These soils can include clays, silts, and silty or clayey sands and gravels, such as the CH, CL, MH, ML, SC, SM, GC, or GM classifications in the USCS, and boundary groups of any two of these defined using dual symbols, e.g., SC-SM. Both compressibility and shear strength of cohesive soils are generally improved by compaction.

### Compaction for cohesionless soils

Cohesionless (also referred to as granular) soils include relatively clean sands and gravels that belong to the SW, SP, GW, and GP USCS classifications, and boundary groups of any two of these soil groups. Because water content doesn't significantly affect the mechanical properties of clean sand and gravel during compaction, the compaction curve from the Proctor test may not correctly show the relationship between maximum density and moisture content for these soil types. Therefore, the principal compaction measure used for cohesionless soils is the relative density ( $D_r$ ) as introduced by Terzaghi (1925);

$$D_r = \frac{e_{max} - e}{e_{max} - e_{min}} \cdot 100\% \quad (1)$$

where

$e_{max}$  = void ratio of the soil in its loosest state

$e$  = void ratio of the soil as tested

$e_{min}$  = void ratio of the soil in its densest state

$D_r$  = relative density, usually expressed as a percentage

Relating void ratio to dry density, Equation 1 can also be expressed as

$$D_r = \frac{\gamma_{dmax}(\gamma_d - \gamma_{dmin})}{\gamma_d(\gamma_{dmax} - \gamma_{dmin})} \quad (2)$$

where

$\gamma_{dmax}$  = dry unit weight of the soil in its densest state

$\gamma_{dmin}$  = dry unit weight of the soil in its loosest state

$\gamma_d$  = dry unit weight of the soil as tested or in situ

Based on the relationship between dry unit weight and porosity ( $n=V_v/V$ ), Eq. 2 may be expressed as

$$D_r = \frac{(n_{max}-n)(1-n_{min})}{(n_{max}-n_{min})(1-n)} \quad (3)$$

where

$n_{max}$  = maximum porosity (loosest state)

$n_{min}$  = minimum porosity (densest state)

$n$  = porosity of the soil as tested or in situ

Terzaghi introduced the compatibility measure of a cohesionless soil, defined as

$$F = \frac{e_{max}-e_{min}}{e_{min}} \quad (4)$$

Terzaghi (1925) and Bejerrum et al. (1960) introduced the idea that the ease of compaction for sands could be evaluated by the compatibility measure and relative density. A larger value of compatibility means that the soil can more easily be compacted.

### Methods of soil stabilization

Soil stabilization is based on physical, chemical, or biological methods for improving certain properties of natural soil using a specific engineering approach. Generally, the processes of soil stabilization involves analysis of the properties of a given soil, finding a specific economical method for modifying the soil, determining feasibility, and using the

method and materials during construction, always considering costs of materials, construction and maintenance. (Hilf, 1991)

Four methods of stabilization offering practical and economical solutions can be categorized as: granular stabilization, chemical stabilization, thermal stabilization, and electrokinetic stabilization. Granular stabilization is a combined method of physical and chemical stabilization to modify the granular bearing skeleton with cementing materials. Chemical stabilization is the oldest and most common method by which chemical compounds are added to the soil to improve its volume stability, strength and stress-strain behavior, permeability, and durability. Chemical reactions, including hydration, ion-exchange, pozzolanic reaction, flocculation, precipitation, polymerization, oxidation, and carbonation, occur between the soil and additives (Hans et al., 1991). Thermal stabilization consists of heating and freezing soil to improve its performance and strength. In electrokinetic stabilization, an electrical potential is applied to soil to induce physiochemical transport of electrical charges, which forms cementing phases in the electric double layer located at the interface of the solid and liquid phases.

Portland cement, lime, fly-ash, and bitumen are used widely as chemical stabilizers. Portland cement, lime, and fly-ash are classified as active agents, and bitumen is an inert agent. The active agents react chemically with the soil, and the inert agents are used to protect cohesive soils from water and to bond cohesionless soil particles together.

Due to economic and environmental considerations, there has also been increased interest in the use of nontraditional stabilizers, which may be divided into six categories: enzymes, lignosulfonates, salts, petroleum resins, polymers, and tree resins (Tingle, et al., 2007). In recent years, natural microbial biological processes have also been applied to

stabilization of loose and collapsible sand (DeJong et al., 2006; Ivanov et al., 2008). The performance of stabilized soil with nontraditional stabilizers has been evaluated by various experimental methods, but further research is needed to develop recommended standards for testing methods, dosages, and field implementation techniques for soil with nontraditional stabilizers.

### **Traditional stabilization**

#### Cement

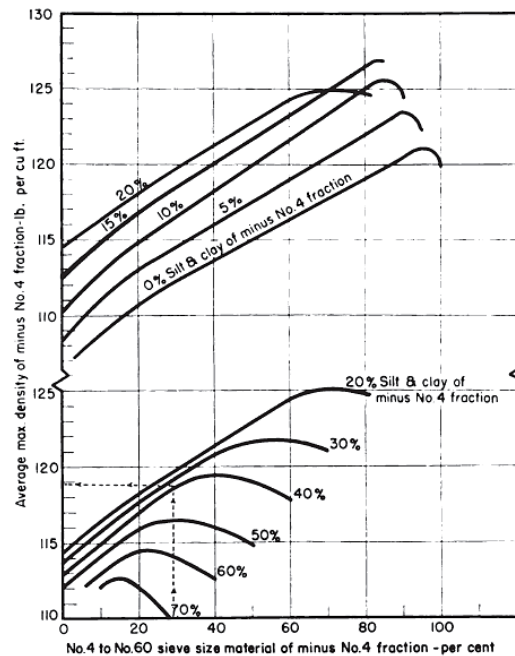
Cement stabilization procedures include mixing and compaction, which change the physical, thermal, and chemical properties of the soil. Portland cement consisting of hydraulic calcium silicates is the most common cement used in cement stabilization. Eight types of portland cement are covered in ASTM C150–12 Standard Specification for Portland Cement. Type I is used for if there is no specified requirement for some other type. Type II is used if sulfate resistance is desired. Type III is used for high-early strength. Type IV is used if low heat of hydration is required, and type V is used for sulfate resistance. (ASTM, 2007)

The amount of portland cement to be used depends on the classification of the soil, as described in Hilf (1991). For well-graded soil, 5% or less cement is needed by dry weight of solids, sandy soil generally requires 7%, non-plastic soils and silts require 10%, and plastic clays require 13%.

A “short-cut” test was developed by the Portland Cement Association (PCA) to determine a safe amount of cement needed for stabilization of sandy soils based on statistical analysis of experimental results for 2,438 soil specimens. The method was developed based on correlations for non-organic soils with less than 50% of material smaller than 0.05 mm (No. 270 sieve, referred to as silt and clay by PCA), and less than 20% smaller than

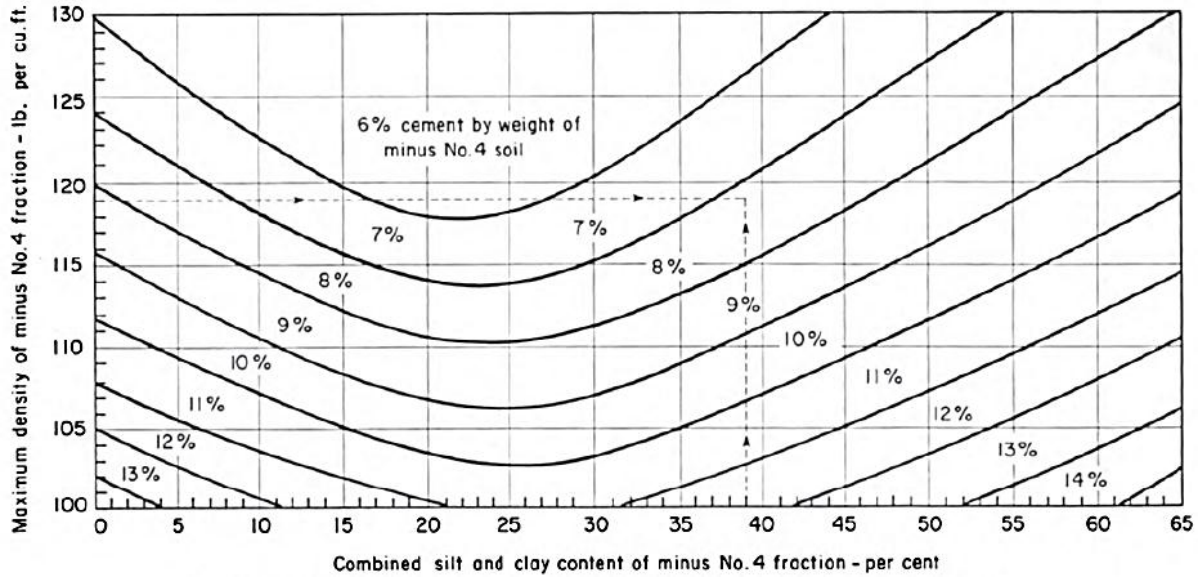
0.005 mm (clay). Therefore, the method should only be applied to soils satisfying these criteria. Note that USCS and AASHTO both currently classify the silt and clay portion as the material smaller than 0.075 mm (No. 200 sieve).

The charts used in the PCA short-cut test procedure Method A (for soils not containing material retained on the No. 4 sieve) are shown in Figures 3, 4, and 5 (Hilf, 1991). First, a sieve analysis of the soil is performed to select the estimated maximum density of the soil-cement mixture from Figure 3. Then the required amount of cement is determined from Figure 4 using the estimated maximum density of the soil-cement mixture and the percent of soil smaller than 0.05 mm. Test specimens are then molded in triplicate at maximum density and optimum moisture content and moist-cured for 7 days, and then their compressive strengths are measured. The average measured compressive strength should be equal or greater than that of Figure 5, determined based on the percentage of material smaller than 0.05 mm (PCA, 1956), or else the cement content should be increased.

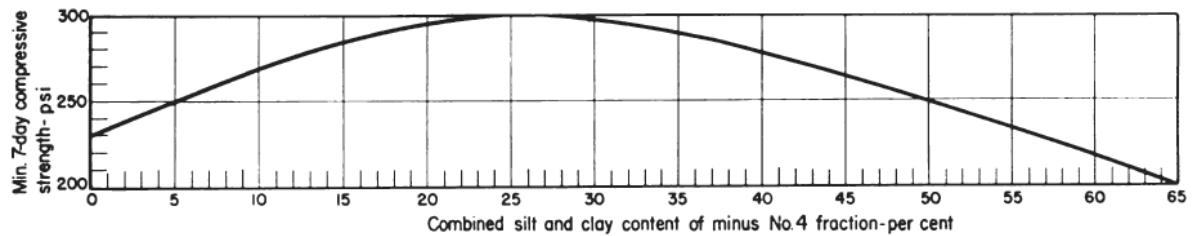


**Figure 3. Average maximum densities of soil-cement mixtures not containing material retained on the No. 4 sieve (from PCA, 1956).**





**Figure 4. Cement content to use in soil-cement mixtures not containing material retained on the No.4 sieve (from PCA, 1956).**



**Figure 5. Minimum 7-day compressive strength required for soil-cement mixtures not containing material retained on the No.4 sieve (from PCA, 1956).**

Different combinations of cement and moisture contents will produce varying degrees of improvement in compressive strength, durability, and density for different soils. To obtain consistent and repeatable results, several ASTM Standards address procedures for soil-cement mixtures. ASTM D1632 provides specifications for making and curing soil-cement compression and flexure test specimens in the laboratory. ASTM D1633 provides specifications for testing the compressive strength of molded soil. The moisture-density relationship of a soil-cement mixture can be determined using ASTM D558, and the freezing and thawing tests of compacted soil-cement mixtures can be tested using ASTM D560. ASTM D559 is the standard for wetting and drying tests of compacted soil-cement mixtures.

### Lime

Lime is another traditional stabilization material composed of calcium and magnesium oxides. There are three processes present in reactions between soil and lime: cation exchange and flocculation-agglomeration, cementation or pozzolanic reaction, and carbonation. Plasticity, workability, uncured strength, and load deformation properties are improved during cation exchange and flocculation-agglomeration, and pozzolanic reactions produce stable calcium silicates and aluminates in reactions between soil and calcium in lime, similar to those occurring with portland cement.

### Fly ash

Fly ash is one of the residues produced by coal combustion, which rises in the flue along with other gases. The composition and physical properties of a particular type of fly ash depends on the coal source and the fueling process used by a power plant. There are two classifications associated with the particular type of coal used; according to ASTM C618, class C fly ash is produced by lignite coal and class F fly ash is produced by bituminous coal. Calcium and sulfate constituents are lower while carbon, silica, and alumina constituents are higher for class F fly ash compared to class C fly ash. The strength of a sub-base or base can be increased using fly ash and lime. Typically, using 12% to 14% fly ash combined with 3% to 5% of lime is an excellent way to stabilize a road base (CMI, 1985).

### Bitumen

Two primary applications are used to stabilize soil with bitumen. For cohesive soil, the soil is modified to make it waterproof, with the appropriate amount of bitumen ranging from 4% to 7%. For cohesionless granular soil, the cement agent provided by bitumen bonds the

soil particles. The optimum amount of bitumen, generally between 4% and 10%, is determined by testing soil density, strength, and water-resistance (Hilf, 1991).

### **Nontraditional stabilization**

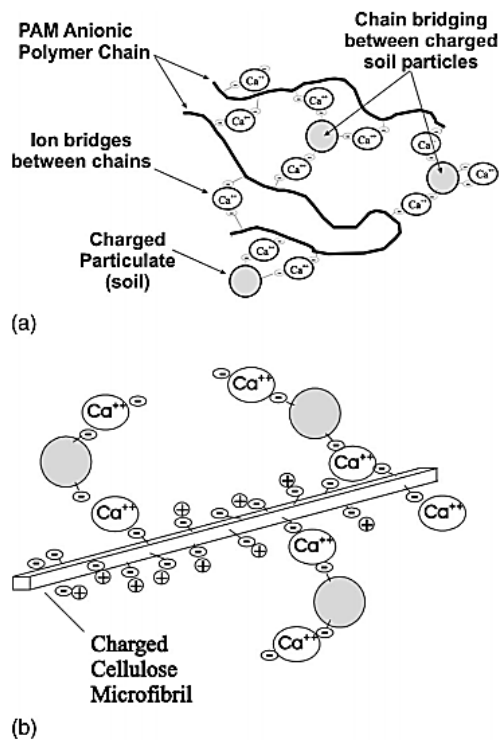
#### Polymers

Polymers are very large molecules consisting of chains of many monomer units. The two main types of polymer; synthetic polymers and natural polymers, are defined by their means of manufacture. Synthetic polymers such as nylon, polyethylene, and silicon are produced by the chemical industry, while natural polymers such as cellulose, proteins, and polysaccharides are produced by living systems. Depending on the combination of monomers present, the structure of a polymer could be linear, branched, or cross-linked. For more details about the biopolymer, two distinct approaches called “bioadvantaged” and “bioreplacement” are introduced and compared in Hernandez et al. (2014). The “bioreplacement” polymers are produced by bio-based monomers, and improved using sugars, starches, lignin, cellulose, and hemicellulose found in trees, plants, and animals to produce the monomer from petroleum. The “bioadvantaged” polymers are made of unmodified or minimally modified vegetable oils, proteins, and some other biological monomers. In a recent study from Williams et al. (2014), the performance properties of base asphalt was significantly improved by a biopolymer produced from acrylated epoxidized soybean oil with radical polymerization techniques, such as reversible addition-fragmentation chain-transfer polymerization.

According to Tingle et al. (2007), polymer stabilizers for soil applications are typically vinyl acetates or acrylic copolymers suspended in an emulsion by surfactants. In their study, the soil particles were first coated by a polymer, then bonded together by the polymer as the

water evaporated. The resulting improvement in strength depended on the physical properties of the polymer, and whether or not the soil was effectively coated by the polymer. The authors reported that the tensile and flexural strengths of the soil can be improved by using polymer, and the moisture susceptibility was also decreased by using a waterproofing polymer.

Orts et al. (2007) reported that polyacrylamide (PAM) copolymers are beneficial for soil stabilization. Three potential mechanisms: columbic charge interaction, hydrogen bonding, and van der Waals interactions, can affect interaction between anionic PAM and soil. Such interaction between PAM and soil happens when the acrylic acid content of PAM rises to 35%. A schematic diagram of the role of charge in interacting with soil particles is shown in Figure 6.



**Figure 6. Schematic depiction of (a) anionic PAM; (b) charged cellulose microfibrils interacting with charged soil particles in the presence of calcium (from Orts et al., 2007).**

Tingle and Stanton (2003) conducted experiments to evaluate the stabilization of low- and high-plasticity clay soils with nontraditional chemical or liquid stabilizers. Twelve nontraditional stabilizers were evaluated, including an acid, enzymes, a lignosulfonate, a petroleum emulsion, polymers, and a tree resin. A total of 12 stabilizers and 7 nontraditional stabilizers at varying concentrations were used to stabilize CL and CH soils. The performance of test specimens relative to control specimens and to one another provided a means for evaluating the effects of stabilizer type, stabilizer quantities, and durability under both wet and dry conditions. The results of the tests also showed that some nontraditional stabilizers significantly improved the unconfined compressive strength (UCS) of the clay materials, but others had no significant effect. From the results of the tests shown in Tables 2 and 3, the cement-stabilized CL samples demonstrated significant strength improvement and resistance to moisture susceptibility, while for the CH soil, the lime-stabilized specimens failed to improve either the dry or wet UCS for all specimens. Overall, these results indicate varying performance by different stabilization additives depending on additive type, additive quantity, soil type, and dry or wet testing conditions.

**Table 2. Unconfined compression test results and density measurements for CH Test Series (from Tingle and Stanton, 2003).**

Stabilizer Type	Application Rate By Dry Weight %	Primary Stabilization Mechanism	Dry Test			Wet Test		
			Water Content %	Dry Density <sup>1</sup> kg/m <sup>3</sup>	Unconfined Compressive Strength, kPa	Water Content %	Dry Density <sup>1</sup> kg/m <sup>3</sup>	Unconfined Compressive Strength, kPa
<b>Control and Traditional Stabilizer Specimens</b>								
None	0.00	None	23.3	1595.4	4736.7	23.3	1593.8	1158.3
Hydrated Lime	3.00	Chemical	23.5	1492.9	1951.2	23.5	1489.7	0 <sup>2</sup>
Hydrated Lime	5.00	Chemical	23.6	1491.3	1641.0	23.6	1496.1	0 <sup>2</sup>
Hydrated Lime	7.00	Chemical	22.4	1464.1	1020.4	22.4	1467.3	0 <sup>2</sup>
<b>Nontraditional Stabilizer Specimens</b>								
Acid 1	0.010	Chemical	22.7	1608.3	4509.2	22.7	1609.9	1151.4
Acid 1	0.050	Chemical	22.6	1621.1	5398.6	22.6	1597.0	827.4
Acid 1	0.100	Chemical	23.7	1598.6	4736.7	23.7	1592.2	861.9
Enzyme 1	0.019	Chemical	23.4	1603.5	4964.3	23.4	1595.4	951.5
Enzyme 1	0.050	Chemical	24.5	1595.4	6039.8	24.5	1597.0	1399.6
Enzyme 1	0.100	Chemical	23.1	1614.7	5557.2	23.1	1613.1	1323.8
Enzyme 2	0.056	Chemical	24.6	1597.0	6074.3	24.6	1593.8	1661.6
Enzyme 2	0.100	Chemical	23.9	1606.7	6274.3	23.9	1601.9	1758.2
Enzyme 3	0.021	Chemical	22.2	1629.1	5267.6	22.2	1624.3	868.7
Enzyme 3	0.050	Chemical	22.3	1597.0	4019.7	22.3	1609.9	1179.0
Enzyme 3	0.100	Chemical	21.9	1605.1	3426.7	21.9	1598.6	1110.1
Enzyme 4	0.010	Chemical	22.6	1608.3	4205.8	22.6	1600.2	1123.9
Enzyme 4	0.020	Chemical	22.5	1608.3	4281.7	22.5	1603.5	2027.1
Enzyme 4	0.100	Chemical	22.8	1613.1	4978.0	22.8	1600.2	1199.7
Polymer 1	0.066	Mechanical	22.8	1617.9	5260.7	22.8	1614.7	1379.0
Polymer 1	2.074	Mechanical	22.3	1582.6	4405.8	22.3	1576.2	1303.1
Polymer 1	5.000	Mechanical	23.5	1579.4	6674.2	23.5	1579.4	4019.7
Polymer 3	1.010	Mechanical	24.3	1557.0	3916.2	24.3	1561.8	1048.0
Polymer 3	2.500	Mechanical	24.2	1557.0	4316.1	24.1	1560.2	2668.3
Polymer 3	5.000	Mechanical	23.7	1525.0	3874.9	23.7	1529.8	1654.8

<sup>1</sup>Dry density remained the same after the 28-day cure period although the moisture content changed due to evaporation.  
<sup>2</sup>Specimen disintegrated when exposed to water. UCS could not be determined.

**Table 3. Unconfined compression test results and density measurements for CL Test Series (from Tingle and Stanton, 2003).**

Stabilizer Type	Application Rate By Dry Weight %	Primary Stabilization Mechanism	Dry Test			Wet Test		
			Water Content %	Dry Density <sup>1</sup> kg/m <sup>3</sup>	Unconfined Compressive Strength, kPa	Water Content %	Dry Density <sup>1</sup> kg/m <sup>3</sup>	Unconfined Compressive Strength, kPa
<b>Control and Traditional Stabilizer Specimens</b>								
None	0.00	None	15.9	1779.7	5033.2	15.9	1781.3	1420.3
Type I Cement	7.00	Both	16.9	1741.2	5005.6	16.8	1733.2	3123.3
Type I Cement	9.00	Both	17.2	1755.6	5633.1	17.9	1754.0	4447.1
Hydrated Lime	3.00	Chemical	17.9	1690.0	2351.1	17.9	1688.3	1103.2
Hydrated Lime	5.00	Chemical	18.5	1688.3	2999.2	18.5	1699.6	1847.8
Hydrated Lime	7.00	Chemical	19.0	1696.4	3440.5	19.0	1701.2	1985.7
<b>Nontraditional Stabilizer Specimens</b>								
Acid 1	0.010	Chemical	14.7	1787.7	5377.9	14.7	1778.1	1379.0
Acid 1	0.050	Chemical	14.9	1778.1	4840.1	14.9	1776.5	1454.8
Acid 1	0.100	Chemical	14.6	1789.3	5246.9	14.6	1789.3	1551.3
Lignosulfonate 1	3.370	Mechanical	15.0	1802.1	6839.6	15.0	1798.9	3564.6
Lignosulfonate 1	5.000	Mechanical	14.8	1808.5	7322.3	14.8	1810.1	4785.0
Lignosulfonate 1	8.000	Mechanical	14.2	1818.1	6108.8	14.2	1818.1	4467.8
Enzyme 1	0.019	Chemical	14.9	1754.0	4502.3	14.9	1758.8	999.7
Enzyme 1	0.050	Chemical	14.8	1750.8	4364.4	14.8	1754.0	986.0
Enzyme 1	0.100	Chemical	14.7	1747.6	4640.2	14.7	1734.8	1172.1
Enzyme 2	0.056	Chemical	15.4	1782.9	5391.7	15.4	1784.5	2151.2
Enzyme 2	0.100	Chemical	14.9	1774.8	4681.6	14.9	1766.8	1861.6
Enzyme 2	0.200	Chemical	15.5	1776.5	5026.3	15.5	1768.4	2813.1
Enzyme 3	0.021	Chemical	14.3	1773.2	4936.7	14.3	1776.5	1337.6
Enzyme 3	0.035	Chemical	14.8	1773.2	5115.9	14.8	1770.0	1592.7
Enzyme 3	0.106	Chemical	14.9	1779.7	5281.4	14.9	1754.0	1447.9
Enzyme 4	0.002	Chemical	14.7	1773.2	5184.9	14.7	1755.6	1199.7
Enzyme 4	0.020	Chemical	15.1	1757.2	4633.3	15.1	1750.8	1082.5
Enzyme 4	0.100	Chemical	14.7	1728.4	5088.4	14.7	1715.6	1144.5
Polymer 1	0.066	Mechanical	15.2	1768.4	5040.1	15.2	1746.0	999.7
Polymer 1	2.074	Mechanical	15.1	1774.8	5295.2	15.1	1766.8	1958.1
Polymer 1	5.000	Mechanical	14.9	1787.7	5977.8	14.9	1782.9	2778.6
Polymer 2	1.252	Mechanical	14.9	1755.6	4840.1	14.9	1755.6	1358.3
Polymer 2	2.500	Mechanical	14.6	1733.2	3399.1	14.6	1725.2	1379.0
Polymer 2	5.000	Mechanical	15.2	1758.8	5115.9	15.2	1752.4	2254.6
Polymer 3	1.000	Mechanical	14.8	1771.6	4454.0	14.8	1768.4	1468.6
Polymer 3	2.500	Mechanical	16.7	1760.4	4909.1	16.7	1747.6	2578.7
Polymer 3	5.000	Mechanical	15.8	1739.6	4364.4	15.8	1734.8	1778.9
Polymer 4	0.104	Mechanical	14.7	1760.4	4488.5	14.7	1762.0	923.9
Polymer 4	2.500	Mechanical	16.7	1714.0	3178.5	16.7	1722.0	1372.1
Polymer 4	5.000	Mechanical	16.0	1657.9	1537.5	16.0	1654.7	0 <sup>2</sup>
Petroleum Emulsion 1	2.530	Mechanical	13.7	1818.1	4550.6	13.7	1818.1	2951.0
Petroleum Emulsion 1	5.000	Mechanical	13.8	1797.3	3454.3	13.8	1792.5	2171.9
Petroleum Emulsion 1	8.000	Mechanical	12.9	1781.3	2109.8	12.9	1787.7	1758.2
Tree Resin 1	7.300	Mechanical	13.2	1742.8	2502.8	13.2	1750.8	1482.4
Tree Resin 1	9.000	Mechanical	12.1	1688.3	1847.8	12.1	1706.0	751.5

<sup>1</sup>Dry density remained the same after the 28-day cure period although the moisture content changed due to evaporation.  
<sup>2</sup>Specimen disintegrated when exposed to water. UCS could not be determined.

Newman et al. (2004) experimented with various emulsion types, and found that ductility for silty sand was increased by the emulsions. The samples were cured at 23 °C and 50% relative humidity for 3 days. The optimum moisture contents for compaction of samples were determined using the modified Proctor test (ASTM D1557). The unconfined

compressive strength, toughness, and retained wet strength were all increased by the polymers compared to cement after 28 curing days. For the UCS, a 2.75% concentration of acrylic vinyl acetate copolymer, polyethylene-vinyl acetate copolymer, and polymeric proprietary inorganic acrylic copolymer exhibited similar UCS to 9% cement after 28 curing days. The toughness of soils with these three additives was also much higher than for the cement. Acrylic vinyl acetate copolymer showed the highest value of toughness after 28 curing days. The retained wet strength and toughness were affected by all of the additives, and the retained wet toughness was higher than for cement-stabilized soil with 28 days curing time. However, from the standpoints of curing time and toughness values, some of the polymers didn't demonstrate optimum material properties with a 28-day curing time.

Al-Khanbashi and Abdalla (2006) determined the effects of waterborne polymers on sandy-soil stabilization with styrene-acrylic, a copolymer emulsion, and vinyl-acrylic copolymer-based emulsions. Hydraulic conductivity, compressive strength, and scanning electron microscope (SEM) measurements were also discussed. To measure the properties, a flexible membrane liquid apparatus was used, and unconfined compression tests and microscopic examinations were conducted. The soil used in the experiment was classified as poorly-graded sand (SP) based on the USCS. According to the Modified Proctor Test Procedure (ASTM 1557), for a polymer content of 5%, the optimum moisture content was 6% and the maximum density was  $1.67 \text{ Mg/m}^3$ . From flexible-wall permeameter tests, the hydraulic conductivity was decreased when the polymer content exceeded 3% by weight, and reached a minimum at 5% polymer content. All the polymers increased the strength and the stiffness of the sand, and the vinylacrylic produced the best effect in terms of increasing the strength and modulus values.



Homaouoni et al. (2011) used polyvinyl acetate and poly methyl methacrylate to stabilize dune sands classified in the SP group according to the USCS. The strength of dune sand was increased by both of the polymers and the results of the California Bearing Ratio (CBR) test showed that the strength in the dry state was better than that in the saturated state. From the analysis, the optimum additive amount of polymer was found to be 3% by dry weight, and the optimum curing time was 28 days.

Naeini et al. (2012) focused on the unconfined compressive strength of clayey soils stabilized with different dosages of waterborne polymers, and described laboratory experiments for testing the effects of curing time, polymer content, and plasticity index. Different dosages of polymers (2, 3, 4 and 5%) were added to three fine-grained clayey samples with different plasticity indexes. The soils were then compacted under optimum water content and maximum dry density conditions (ASTM D-1557). Strengths with different curing times (2, 4, 6, 8 and 14 days) were determined by unconfined compression tests according to ASTM D2166. The unconfined compressive strength increased rapidly during the first 8 days, then remained constant for 14 days. The unconfined compressive strength increased with the polymer content, and reached a maximum at a polymer content of 4%. The plasticity index is another important parameter that affects unconfined compressive strength. Based on the test results, a higher polymer content could affect the stress-strain behavior of soil samples by changing them from brittle to ductile behavior due to an increase in plasticity index. For application in roadways, a 4% polymer content and 8-day curing time were recommended for soil stabilization.

### Microbial stabilization

Microbial stabilization is an emerging biological method for soil stabilization, and microbes constitute the largest biomass on earth (Karol, 2003). Generally, the microorganisms which biodegrade complex compounds in soil and water are bacteria and fungi. Some engineering properties are improved by natural microbial biological processes, and the cost of microbial stabilization tends to be lower than that of other methods.

The process of microbial stabilization cements the sediments consisting of calcium, magnesium, iron, manganese, and aluminum through a network of chemical reactions, and the engineering properties of soil are altered by the byproducts of these reactions (DeJong et al., 2006). The permeability, stiffness, compressibility, shear strength, and volumetric behavior are improved in such bio-mediated systems. The permeability is reduced by  $10^{-3}$ , and the shear strength and stiffness are increased by  $10^2$ , according to results reported for bio-mediated improvement processes (DeJong et al., 2010).

The improvement of soil properties through microbial stabilization has been achieved in many areas such as liquefaction mitigation, settlement reduction, and slope stabilization. In addition, some environmentally-friendly factors such as energy storage and carbon sequestration are also provided by bio-mediated systems (DeJong et al., 2010). However, some drawbacks exist for microbial stabilization: the process is usually slower and more complex compared to chemical grouting; the time rate and various environmental factors such as temperature, pH, and concentrations of donors must be better-controlled during the deployment of microbial stabilization approaches (Ivanov et al., 2008).

## Shear strength of soil

### Mohr-Coulomb Failure criterion

Mohr (1900) introduced a theory that neither the maximum normal nor the shear stress is the cause of soil failure, but a combination of normal stress and shear stress. Coulomb (1776) found that the relationship between the normal stress and shear stress at failure can be described by a linear function for typical soil mechanics problems;

$$\tau_f = c + \sigma \tan \phi \quad (5)$$

where

$c$  = cohesion

$\phi$  = angle of internal friction

$\sigma$  = normal stress on the failure plane

$\tau_f$  = shear strength (shear stress on the failure plane)

Equation 5 is referred to as the *Mohr-Coulomb failure criterion*. In terms of effective stress, the Mohr-Coulomb failure criterion can be expressed using the drained cohesion  $c'$  and effective normal stress  $\sigma'$  as

$$\tau_f = c' + \sigma' \tan \phi' \quad (6)$$

The typical linear relationship between the shear stress and the effective normal stress is shown in Figure 7. The theoretical angle between the major principal plane and the plane of failure is

$$\theta = 45^\circ + \frac{\phi'}{2} \quad (7)$$

Cohesion of sands and inorganic silts as well as normally consolidated clays is generally taken to be zero. Table 4 shows typical values of drained angles of friction for sands and silts, and Table 5 shows an example of triaxial test results for some normally consolidated clays.

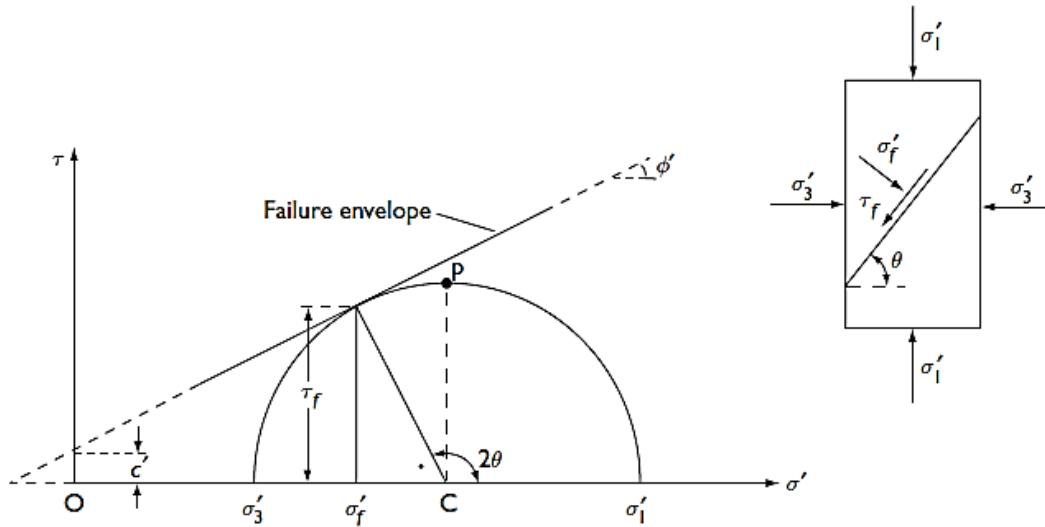


Figure 7. Mohr-Coulomb failure criterion (from Craig, 2005).

Table 4. Typical values of drained angle of friction for sands and silts (from Das, 2010).

Soil type	$\phi'$ (deg)
<i>Sand: Rounded grains</i>	
Loose	27–30
Medium	30–35
Dense	35–38
<i>Sand: Angular grains</i>	
Loose	30–35
Medium	35–40
Dense	40–45
<i>Gravel with some sand</i>	34–48
<i>Silts</i>	26–35

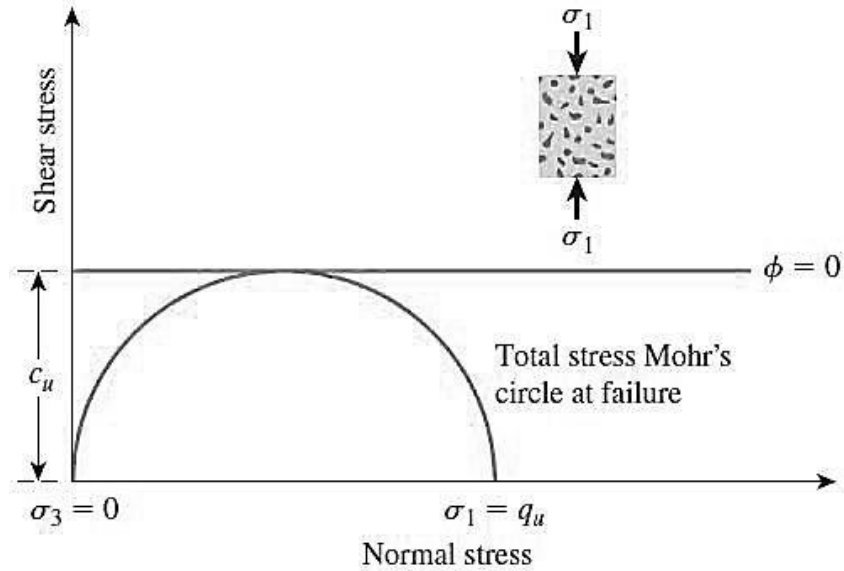
**Table 5. Triaxial test results for some normally consolidated clays obtained by the Norwegian Geotechnical institute (from Das 2010).**

Location	Liquid limit	Plastic limit	Liquidity index	Sensitivity <sup>a</sup>	Drained friction angle, $\phi'$ (deg)	$\bar{A}_f$
Seven Sisters, Canada	127	35	0.28		19	0.72
Sarpborg	69	28	0.68	5	25.5	1.03
Lilla Edet, Sweden	68	30	1.32	50	26	1.10
Fredrikstad	59	22	0.58	5	28.5	0.87
Fredrikstad	57	22	0.63	6	27	1.00
Lilla Edet, Sweden	63	30	1.58	50	23	1.02
Gtå River, Sweden	60	27	1.30	12	28.5	1.05
Gtå River, Sweden	60	30	1.50	40	24	1.05
Oslo	48	25	0.87	4	31.5	1.00
Trondheim	36	20	0.50	2	34	0.75
Drammen	33	18	1.08	8	28	1.18

Several tests for determining shear strength have been developed over the past century, including the direct shear test, triaxial test, direct simple shear test, plane strain triaxial test, and torsional ring shear test. Generally, the direct shear and triaxial tests are most often used to determine the shear strength.

### Unconfined compressive strength

The unconfined compression test is a special case of an unconsolidated-undrained triaxial test in which the confining or cell pressure is zero relative to atmospheric pressure (Holtz et al., 2011). Figure 8 shows the major principal stress on the specimen at failure for the test conducted according to the ASTM D2166. There are two typical types of failure from the unconfined compression test, i.e., distinct failure planes for stiffer specimens, and barreling behavior for softer specimens.



**Figure 8. Unconfined compression test (from Das, 2010).**

### Direct shear test

The direct shear test was used by Coulomb more than 230 years ago to determine the necessary parameters for his strength equation (Holtz et al., 2011). The direct shear box has two separated horizontal halves, with the bottom half fixed and the top half pushed or pulled horizontally, as shown in Figure 9. A normal load is applied on the load cap, and shear stress and vertical and horizontal deformation are measured according to ASTM D3080. Typical direct shear test results for dense and loose sands are shown in Figures 10 and 11.

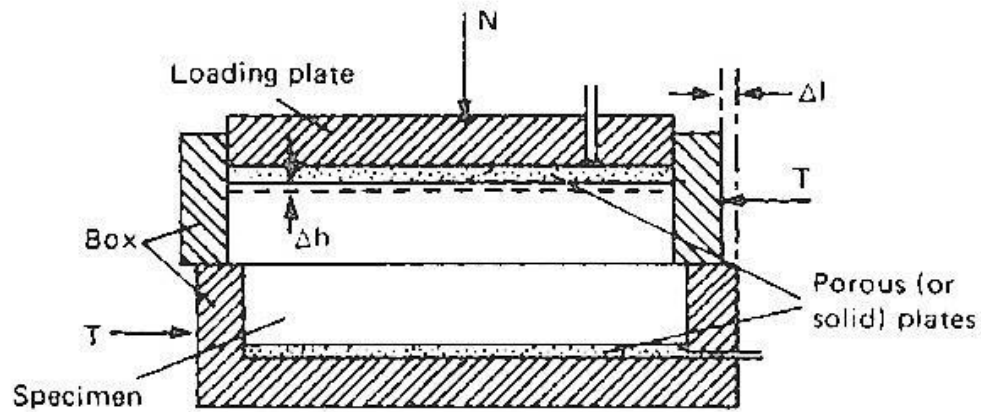


Figure 9. Direct shear apparatus and measured forces and displacements (from Craig, 2005).

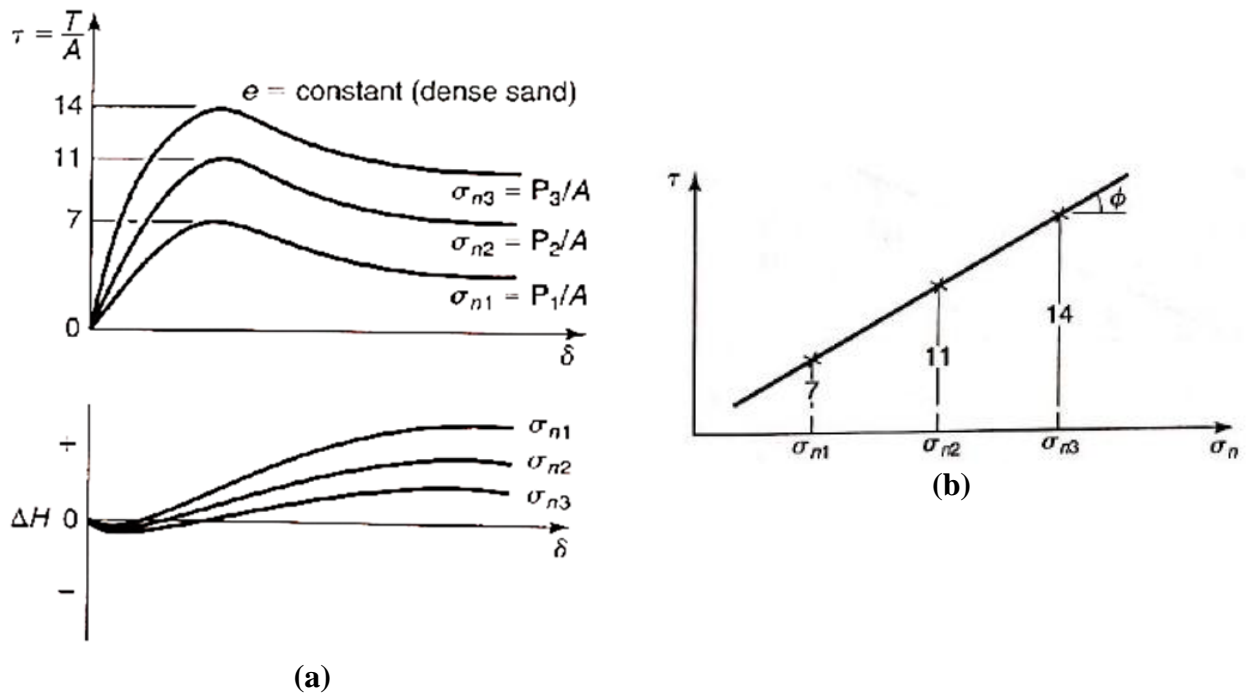
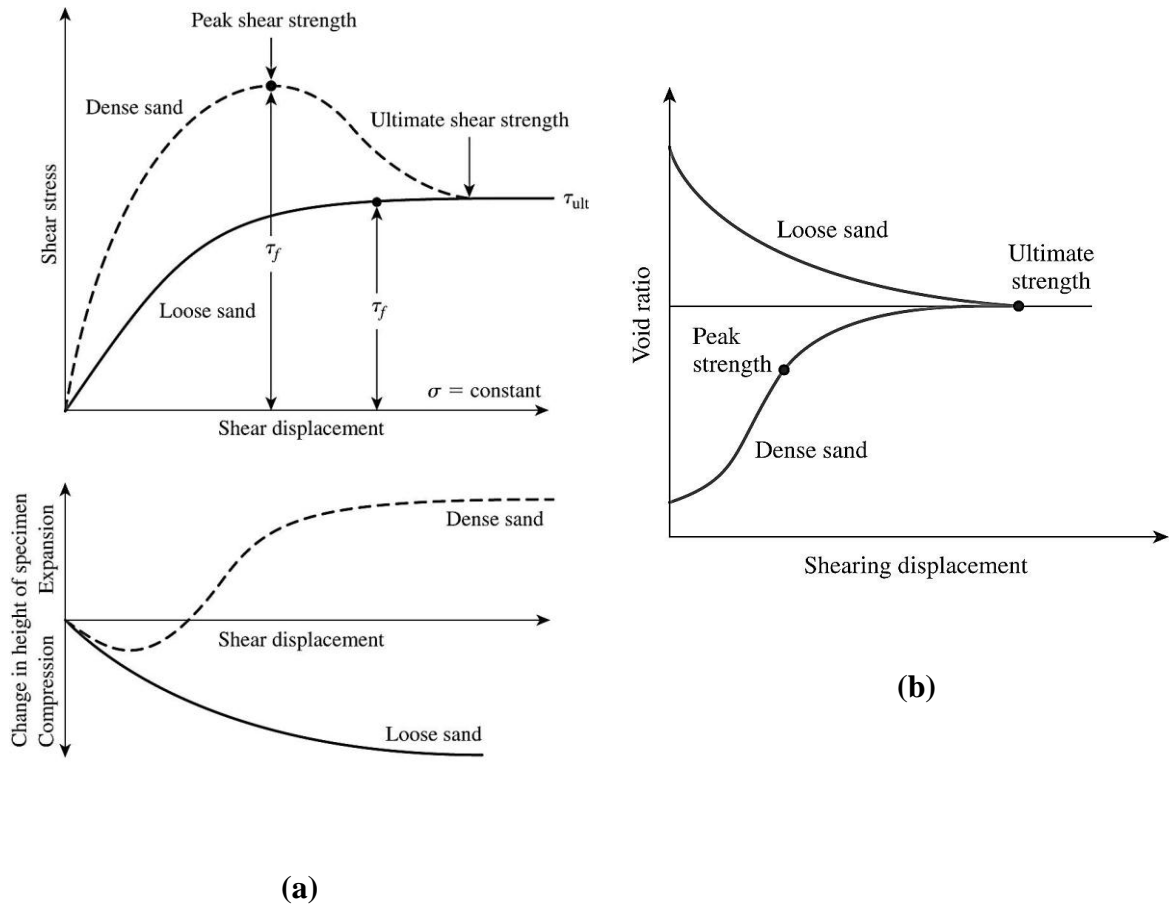


Figure 10. Typical direct shear test results for dense sand; (a) shear stress and height change versus shearing displacement for specimens at the same initial relative density; (b) Mohr-Coulomb failure envelope (from Holtz et al., 2011).



**Figure 11. Typical direct shear test results for dense sand with different initial void ratios (loose vs. dense) and same vertical stress (a): shear stress and volume change vs. shear displacement, (b): void ratio vs. shear displacement (from Das, 2010).**



## CHAPTER 3. MATERIALS AND METHODS

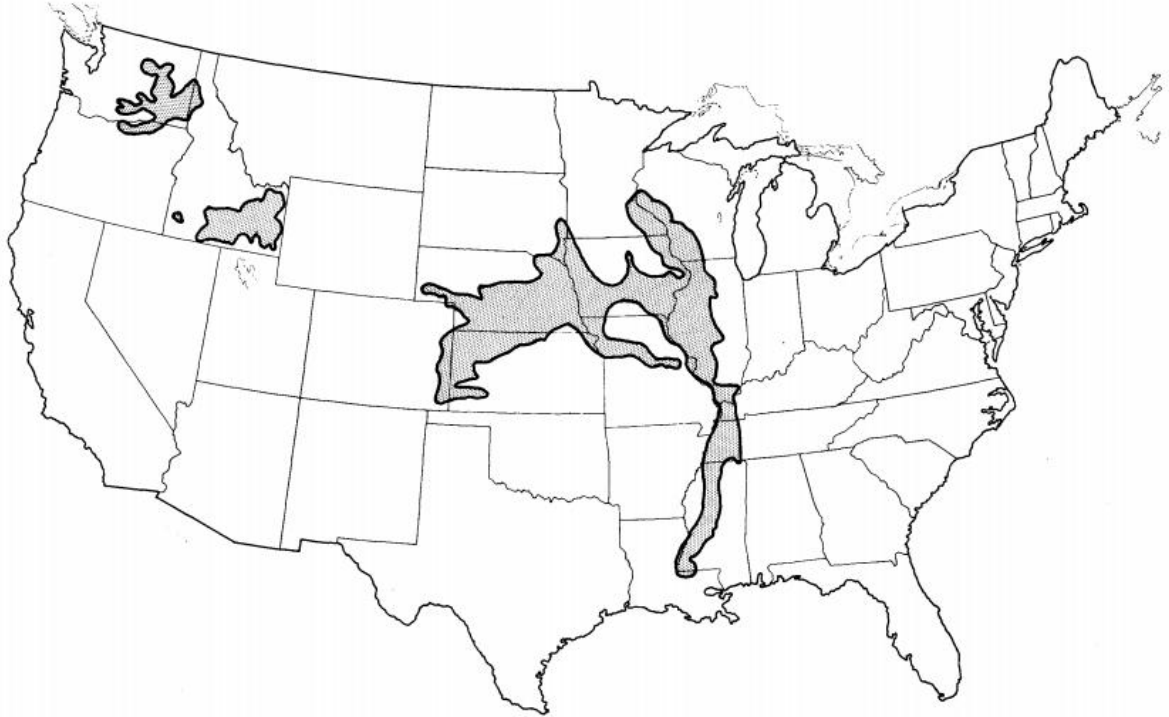
The performance of two types of soil with varying amounts of monomer, polymer, and cement was evaluated to explore their behavior using both traditional and nontraditional stabilization methods. Two specific kinds of soil were used for tests: western Iowa loess (a wind-blown silt) and Ottawa 20-30 sand. Stabilization properties of the soil types were determined by compaction tests, unconfined compression tests, and direct shear tests. These materials are described in this chapter, and the various preparation methods are introduced.

### Test Materials

#### Western Iowa loess (Silt)

Western Iowa loess is an aeolian silt from the Missouri river basin, and is composed of feldspar, quartz, mica and other minerals (USGS, 1999). It primarily consists of cohesionless silt-sized particles, but can possess cohesion if clay minerals are present. Loess materials comprised entirely of cohesionless silt particles can also exhibit apparent cohesion at low moisture contents due to negative capillary pressure which is lost upon wetting, or due to negative pore pressures caused by dilation during shearing. Therefore, if the moisture content of loess increases sufficiently, the material can lose its apparent cohesion and be prone to collapse. This soil material was chosen for the stabilization study based on extensive past research regarding its susceptibility to collapse and its stabilization potential. A significant volume of research on loess is available in the engineering literature, including test results regarding particle size analysis, specific gravity, Atterberg limits, and stabilization performance. (e.g., El Howayek et al., 2011)

Loess is distributed widely throughout the world, and is found in such places as England, USA, China, Belgium, Iran, China, and Thailand (Eden et al., 1988). Figure 12 displays Loess deposits in the United States and shows that Iowa is one of the regions where this type of soil is most extensively found.

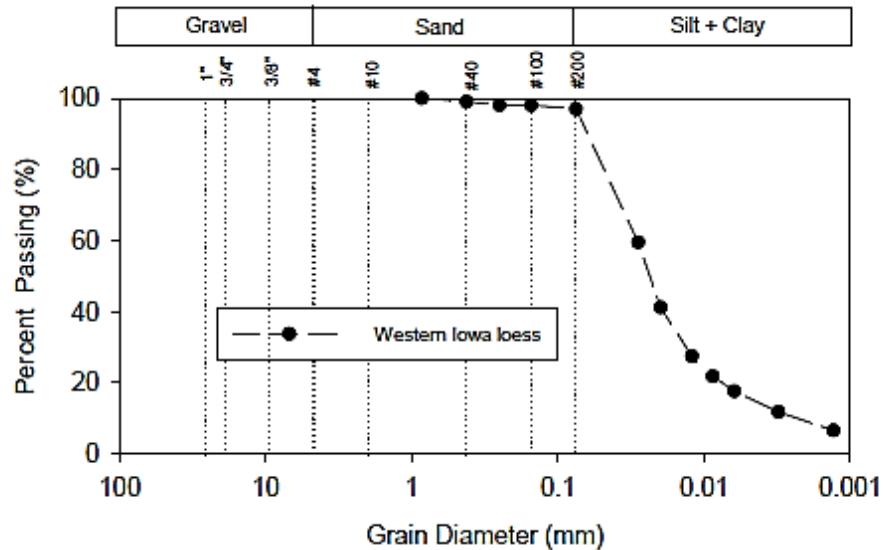


**Figure 12. Outline of major loess deposits in the United States (from Gibbs et al., 1960).**

The structure of loess is very loose, with high void ratios. Certain moisture and load combinations can induce stability, collapse, seepage, erosion, and problems related to large consolidation (Gibbs et al., 1960).

Previous research has indicated that the specific gravity ( $G_s$ ) of western Iowa loess is 2.72, its liquid limit (LL) is 29%, and its plastic limit (PL) is 23% (Li, 2013). According to AASHTO classification, loess belongs to the A-4(0) group. The USCS group symbol for loess is ML, designating silty sand. Figure 13 shows the particle-size distribution of western

Iowa loess. The optimum moisture content and maximum dry density were determined in this study using compaction tests whose methods and results will be described in later chapters.



**Figure 13. Particle size distribution curve of western Iowa loess (from Li, 2013).**

There are several potential ways to stabilize western Iowa loess against the types of problems described above, including both traditional and nontraditional stabilization methods. Loess stabilized by cement and fly ash, bottom ash, or rice-husk ash has been shown to perform better than crushed rock in terms of California Bearing Ratio (CBR) and settlement in plate load tests, making it suitable as a road base course (Sirichai et al., 2010). In the present study, stabilization of loess was examined using monomers and polymers with various curing methods.

#### **Ottawa sand (ASTM 20-30 sand)**

Ottawa 20-30 sand is a standard sand for testing hydraulic cements, which is specified by ASTM C778-13 and widely used in geotechnical laboratory testing. As its name implies, this sand consists of uniformly-sized particles between the No. 20 and 30 sieves (Figure 14). Based on sieve analysis, the AASHTO classification for this soil is A-1-b and the USCS



## Monomers

An acrylated glycerol monomer was used in this study to modify the engineering properties of the loess soil. The glycerol was chemically modified with acrylic acid in the presence of a free radical inhibitor (hydroquinone) and a base catalyst (triphenyl phosphine). Two versions of this monomer were used to evaluate the compressive strength of loess, one a water-soluble acrylated glycerol monomer, the other a “soft block” type polymer (Forrester, 2014). The monomers and polymers used were proprietary experimental materials currently being developed by researchers in the Departments of Chemical and Biological Engineering and Civil, Construction and Environmental Engineering at Iowa State University.

The water-soluble acrylated glycerol monomer was applied at a 2% to 4% addition by dry soil weight. In order to reduce its viscosity and improve its dispersion, the liquid monomer was dissolved in water at 60 °C prior to being mixed with the loess by hand. The amount of water used assumed a 1:1 monomer to water replacement ratio by weight, such that the sum of water-soluble acrylated glycerol monomer and water corresponded to the optimum moisture content of the loess.

## Biopolymers

Biopolymers are natural polymers formed by monomer units consisting of carbon compounds. The most typical source of biopolymers is polysaccharides, but other sources such as algae and microbes can also be used to produce a biopolymer. The glycerol of the biopolymer was allowed to polymerize in the presence of a reversible addition-fragmentation transfer (RAFT) agent, or chain transfer agent (CTA). An initiator was added to remove the free-radical inhibitors and a solvent (methanol) was added to achieve the correct solution

concentration (Forrester, 2014). This material is also known as a “soft-block” type polymer, meaning that it is very elastic with a high capacity for stretching before mechanical failure.

In this study, the ability of the biopolymer to increase the shear strength and ductility of Ottawa sand was investigated by direct shear tests, using addition rates from 1% to 4% biopolymer by dry soil weight.

### **Cement**

To gauge the stabilization performance of the biopolymer against conventional stabilization methods for sands, Lafarge Type II portland cement was also used to stabilize the Ottawa 20-30 sand in direct shear tests. This type of cement is often selected for general use, especially when moderate sulfate resistance or moderate heat of hydration is desired.

The cement dosage was determined from both previous research and the PCA short-cut method described in the previous chapter (Portland Cement Association, 1971). Based on particle-size analysis and the maximum dry density of the Ottawa 20-30 sand, the optimum cement content determined using the short-cut method was 12% to 13% by dry soil weight. A similar range of 8% to 10% was reported in previous research studies (Rahman et al., 2008).

## **Test Methods**

### **Specimen preparation**

Different mixing procedures, compaction methods, and curing methods were used to prepare stabilized soil specimens for the various materials and tests. The untreated and stabilized soil specimens using variable amendment and water contents were tested to observe and compare the behavior of the stabilized soils.

### Western Iowa Loess

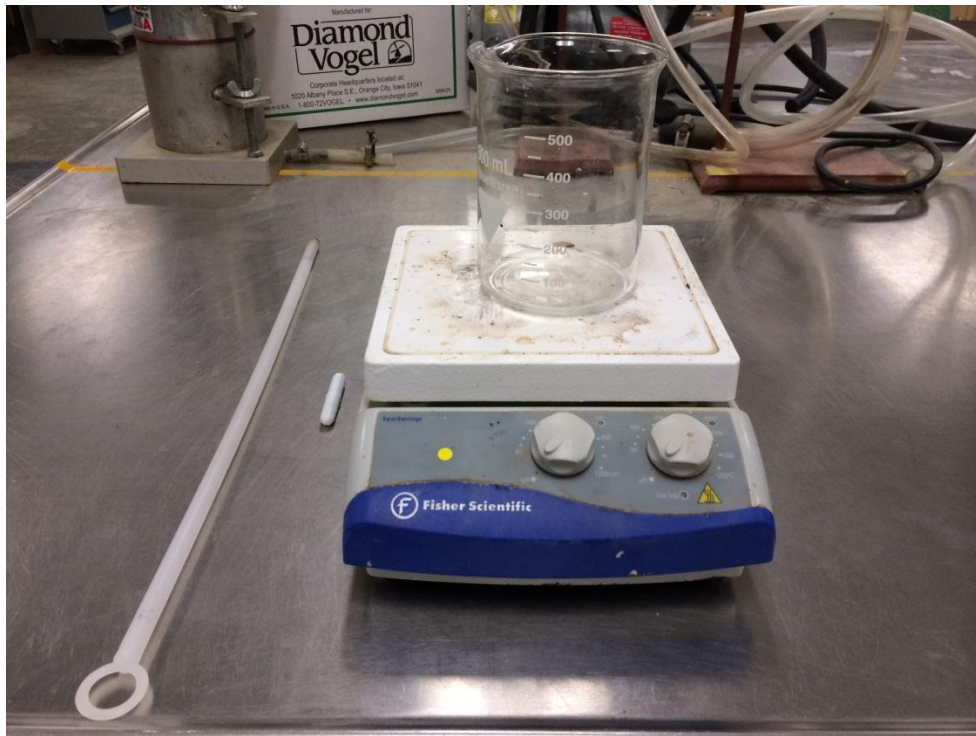
For the Western Iowa loess, both untreated and stabilized specimens were tested for unconfined compressive strength. Triplicate specimens for each combination of water and additive content were prepared to assess the repeatability and statistical variation of test results. During the mixing procedure, water was sprayed onto the soil using a spray bottle to keep the moisture content of the soil as uniform as possible. The original water content of the air-dried determined to be 2.99%, as tested according to ASTM D4643. For the specimens with polymer and monomer, the amendment was diluted with water and the percent of additive varied from 2% to 4% measured by dry soil weight.

To determine the strength of the untreated and stabilized soils, specimens were cured for periods of 1 hour, 1day, 7 days, and 28 days under uniform temperature and humidity conditions. A room temperature of approximately 24 °C was selected for the curing temperature. An air-drying method was used during the curing to provide conditions similar to those in the field (Newman et al., 2004).

### Ottawa (ASTM 20-30) sand

The untreated Ottawa sand specimens were prepared at their air-dry moisture content and directly tested in the direct shear device. The initial moisture content of the air-dried Ottawa sand was determined to be 0% according to ASTM D4643. The stabilized sand specimens were compacted by hand inside direct shear and oedometer rings using a wooden tamp. Because of material variations, different curing methods were used for the Ottawa sand with added polymer and cement. Specimens were prepared at optimum moisture content (OMC) minus 2% for the direct shear tests.

As mentioned above, the polymer was first diluted with the required amount of water before mixing with soil, as it was originally in a semi-solid plastic form prior to preparation. Based on the supplier's recommendation, the temperature of the water used for diluting the polymer ranged from 60 °C to 90 °C. A hot-plate with magnetic stirrer apparatus was used to mix the water and polymer (Figure 15). A beaker of water was first placed on the hot plate, and the monomer or polymer was added when the water temperature reached 60 °C. The magnetic stirrer was then used to mix the polymer and water at a uniform speed for 30 minutes.



**Figure 15. Hot-plate and magnetic stirrer apparatus for mixing glycerol monomers/polymers with water.**

All the direct shear Ottawa sand specimens with polymer were compacted by hand within the direct shear or oedometer rings placed on a steel plate as shown in Figure 16. To decrease air voids and achieve uniform densities of the specimens, three layers were used during compaction. The specimens with polymer were compacted directly in the shear ring at



OMC minus 2%, and their moisture contents were allowed to decrease during curing in the oven. The oven curing temperature for Ottawa sand with polymer was chosen to be 43 °C (110 °F) for 3 days, based on results of previous research (Newman et al. 2004).

For Ottawa sand with cement, three layers were also used during compaction. Prior to compaction, plastic wrap and aluminum foil were placed under the oedometer and direct shear rings, as shown in Figure 17. Additionally, the metal rings were lined with strips of paper to prevent the specimens from becoming cemented to the rings, thus enabling them to be released without damage. After compaction, the specimens and rings were wrapped in the plastic wrap and aluminum foil to retain their moisture and then cured at room temperature for 7 days.



**Figure 16. Preparation method for the polymer-stabilized sand specimens.**



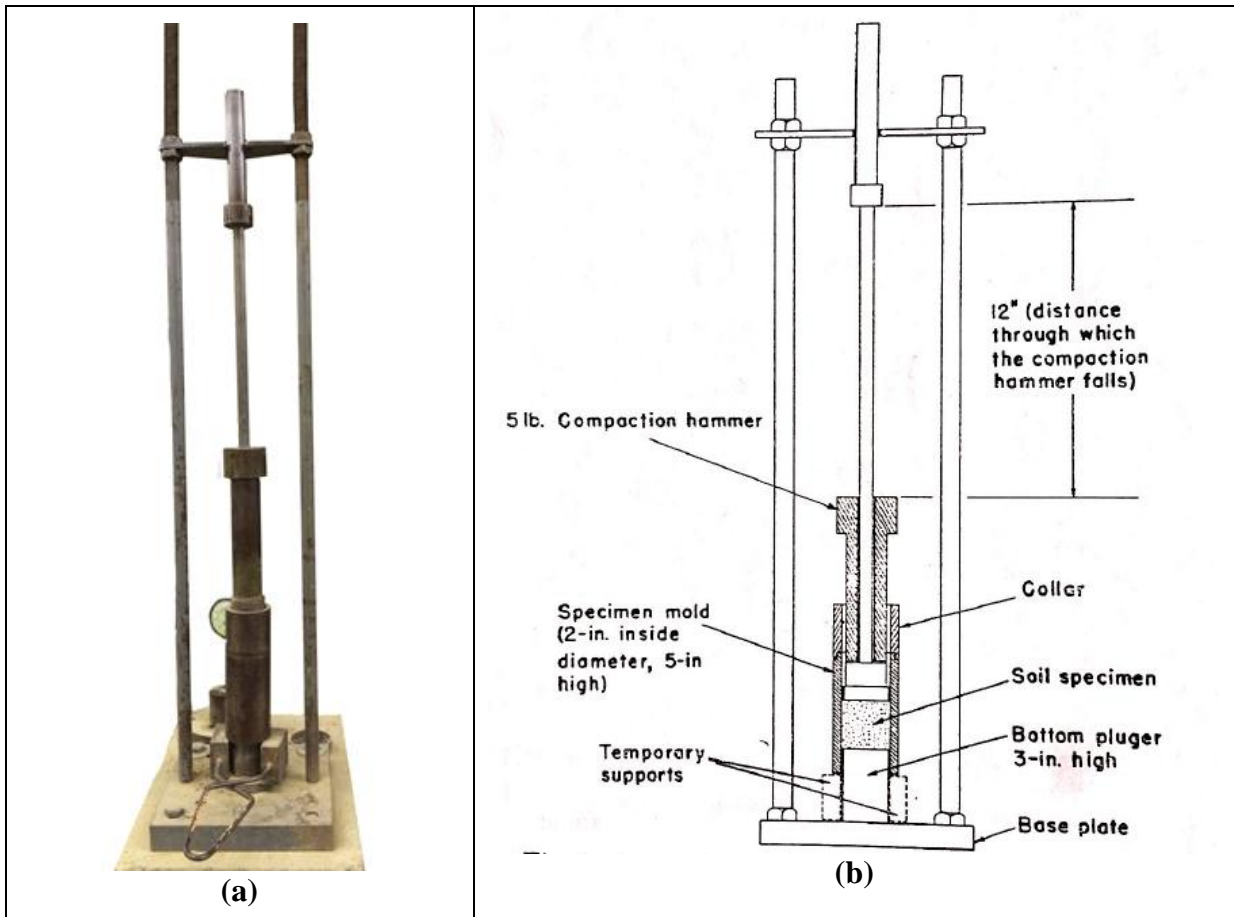
**Figure 17. Preparation method for the cement-stabilized sand specimens.**

### **Compaction test**

As described Chapter 2, a compaction test is a basic procedure for evaluating the optimum moisture content and corresponding maximum dry density of soils based on experimentally measured compaction curves (ASTM D698 and D1557). The optimum moisture content was one of the important parameters for specimen preparation in this study. The Standard Proctor compaction test (ASTM D698) is the most common compaction test, and was used to determine the optimum moisture content and corresponding dry density for Ottawa sand. For Western Iowa loess, a more efficient compaction procedure developed for fine-grained soils was employed (Chu and Davidson 1966), which uses smaller specimens to save both time and materials.

Western Iowa Loess

The compaction method used for Western Iowa loess was a modified version of the ISU 2×2 compaction test using the apparatus shown in Figure 18. The specimens from this compaction procedure were not only used to determine the optimum moisture content, but also for the unconfined compressive strength tests.



**Figure 18. ISU 2×2 compaction device: (a) photo, and (b) schematic (from O'Flaherty et al. 1963).**

The ISU 2×2 compaction device produces specimens that are 2 inches in diameter by 2 inches in height. For this device, a 5-pound hammer is dropped from a height of 12 inches to deliver 10 blows, and the specimen is placed in a single layer. This provides a compaction energy per unit volume of 13,750 ft-lbf/ft<sup>3</sup>;

$$\text{Energy}_{\text{impact}} = \frac{\text{No. of blows} * \text{weight of hammer} * \text{height of drop}}{\text{Volume of sample}} \quad (8)$$

$$= \frac{10 * 5 \text{ lb} * 12 \text{ in} * \frac{1 \text{ in}}{12 \text{ ft}}}{\left(\frac{2 \text{ in}}{2}\right)^2 * \pi * 2 \text{ in} * \left(\frac{1 \text{ in}}{12 \text{ ft}}\right)^3} = 13,750 \text{ ft-lbf/ft}^3$$

which is slightly higher than the compaction energy of 12,400 ft-lbf/ft<sup>3</sup> specified in the Standard Proctor compaction test (ASTM D698). However, the unconfined compression test Standard ASTM D2166 specifies a minimum acceptable height-to-diameter ratio of 2:1. Therefore, the ISU 2×2 compaction device was used, but the size of the specimen was increased to 2 inches in diameter by 4 inches in height for the modified 2×4 ISU compaction device method. Additionally, the soil was compacted using two layers for the modified method, with 10 blows per layer, to achieve the same compaction energy per unit volume. The compaction energy for the modified 2×4 method is therefore also 13,750 ft-lbf/ft<sup>3</sup>;

$$\text{Energy}_{\text{impact}} = \frac{\text{No. of blows} * \text{weight of hammer} * \text{height of drop}}{\text{Volume of sample}} \quad (9)$$

$$= \frac{20 * 5 \text{ lb} * 12 \text{ in} * \frac{1 \text{ in}}{12 \text{ ft}}}{\left(\frac{2 \text{ in}}{2}\right)^2 * \pi * 4 \text{ in} * \left(\frac{1 \text{ in}}{12 \text{ ft}}\right)^3} = 13,750 \text{ ft-lbf/ft}^3$$

The results from compaction tests using the Standard Proctor compaction test (ASTM D698), the ISU 2×2 compaction test, and the modified 2×4 test will be compared later in the results section.

#### Ottawa sand (ASTM 20-30 sand)

To determine the relationship between water content and dry unit weight for Ottawa sand, a Standard Proctor compaction test was conducted. This test followed ASTM D698, Standard Test Methods for Laboratory Compaction Characteristics of Soil Using Standard

Effort (12,400 ft-lbf/ft<sup>3</sup> (600KN-m/m<sup>3</sup>). The size of the mold was 4 inches (101.6mm) in diameter, 4.584 inches (116.4mm) in height, and 0.0333 ft<sup>3</sup> (944cm<sup>3</sup>) in volume. The weight of the hammer was 5.5-lbf (24.4N), and it was dropped from a height of 12 inches (305 mm). During compaction, three layers were compacted using 25 blows for each layer. The corresponding compaction energy from Equation 1 is 12,400 ft-lbf/ft<sup>3</sup>.

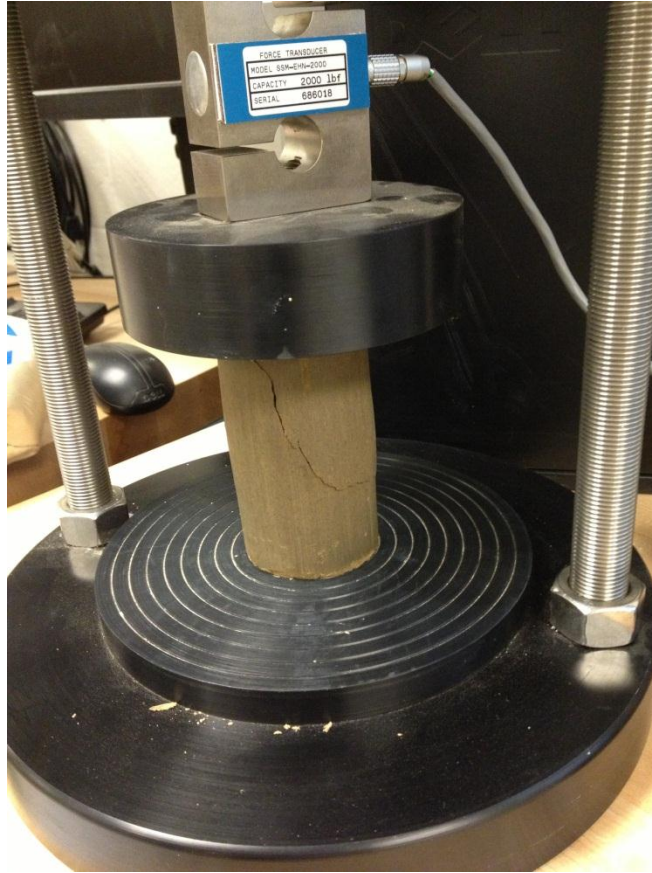
To determine the maximum dry unit weight and optimum moisture content, each compaction specimen was oven-dried for a period of at least 24 hours at a temperature of  $230 \pm 9$  F ( $110 \pm 5$  °C) after measuring its compacted moist weight. Compaction curves were then plotted for the tested moisture contents and the corresponding calculated dry unit weights.

### **Evaluation of strength**

Both the unconfined compression test and the direct shear test were used to evaluate the strength behavior of the materials. As discussed above, loess can possess cohesion or apparent cohesion, which enables the use of unconfined compression tests for measurement the undrained shear strength. For the Ottawa sand, which is a non-plastic soil, the direct shear test was used to determine the drained shear strength parameters; cohesion ( $c'$ ) and angle of internal friction ( $\phi'$ ).

#### *Unconfined compression test (Loess)*

The unconfined compressive strength was determined according to ASTM D2166, which specifies the standard test method for unconfined compressive strength of cohesive soil. Figure 19 shows the device used for the unconfined compressive strength determination. All the data for plotting the stress-strain graphs were computer-recorded.



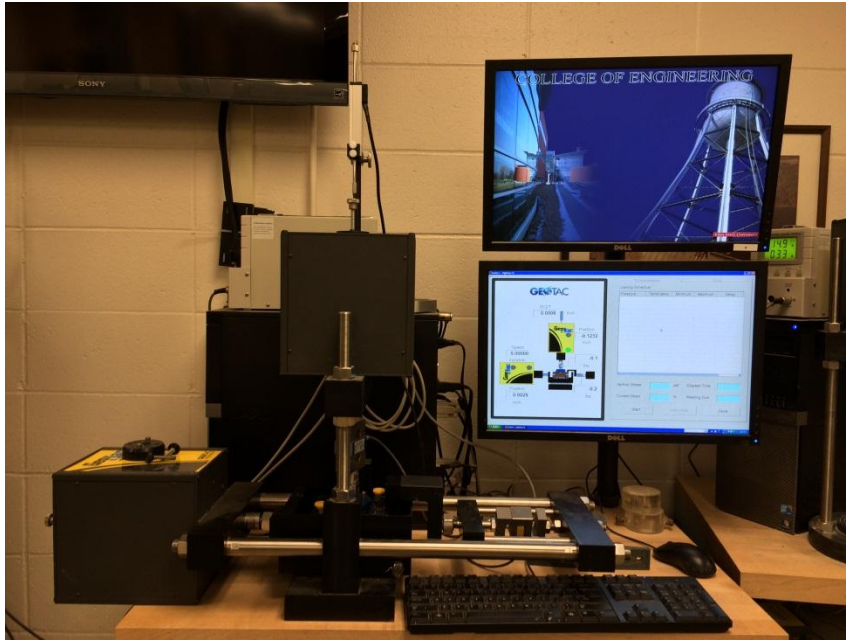
**Figure 19. Geotac automated equipment used for unconfined compression tests.**

Before testing, the specimens were prepared following the procedures described above for specimen compaction. As described there, specimens were cured at room temperature for a period of 1 hour, 1 day, 7 days, or 28 days prior to an unconfined compression test. Specimens were compacted at their optimum moisture content as determined by the compaction tests. The diameter and height of the sample were measured and recorded at three different points on each specimen, and the load cell and position indicator were zeroed before each test.

The loading strain rate was set between 0.5% and 2% per minute so that the failure time would not exceed 15 minutes. The unconfined compressive strength was identified when either the compressive stress reached a peak value or a limiting strain of 15% was reached.

Direct shear test (Ottawa sand)

The direct shear test was conducted to determine the shear strength of sand as specified in ASTM D3080–Standard Test Method for Direct Shear Test of Soils under Consolidated Drained Conditions. Figure 20 shows the automated direct shear testing apparatus used to determine the shear strength of the untreated and polymer-modified sand specimens.



**Figure 20. Geotac automated direct shear test device.**

For the dry untreated Ottawa sand specimens, the weight and volume of the sample in the shear box were measured, and their ratio was used to calculate the actual dry unit weight  $\gamma_d$ . The target relative density for the sand was 40%, which was the maximum achievable relative density in this research for sand compacted in the direct shear ring using a wooden hand tamper. The target sample height was 1 inch, while the shear box diameter was 2.5 inches. The target void ratio for a relative density of 40%, determined from the equation

$$\text{Relative density } D_R = \frac{\text{Maximum void ratio} - \text{void ratio}}{\text{Maximum void ratio} - \text{Minimum void ratio}} = \frac{e_{max} - e}{e_{max} - e_{min}} \quad (10)$$

with an assumed specific gravity  $G_s=2.65$  and the properties given in Table 5, was  $e=0.646$ . This void ratio was then substituted along with the known volume ( $V$ ) into the relation

$$\text{Dry unit weight } \gamma_d = \frac{G_s \gamma_w}{1+e} = \frac{M_d}{V} \quad (11)$$

from which the required dry mass of sand ( $M_d$ ) needed for a relative density of 40% was determined to be 129.51 grams for a specimen exactly 1 inch in height. However, a small amount of sand was typically lost by adhering to the containers and tools during mixing with the various stabilizers, and the polymer matrix tended to bulk up the specimens during curing, which increased the distance between the solid particles and gave the specimens a final height greater than 1 inch. This makes it difficult to determine the actual mass of dry sand particles in a given cured specimen. Therefore, the relative density of the sand fraction was estimated based on the actual measured mass and dimensions of the polymer-amended specimens after curing, as shown in Table 7. In preparing the specimens, 140 grams of dry sand was first weighed and the necessary mass of water and polymer (assuming a 1:1 water to polymer replacement ratio by mass) was added to reach the target 13% OMC (i.e., 12% water with 1% polymer, 11% water with 2% polymer, or 9% water with 4% polymer). It was assumed that the water added during mixing was completely driven off during curing of the specimen in the oven, so that the final measured mass in Table 7 consisted of sand plus the added percentage of polymer. The mass of the sand fraction in the cured specimen (Table 8) was therefore estimated by dividing the measured total mass of the cured specimen by one plus the polymer percentage. The measured height of the cured specimen (sand plus polymer) was then used to calculate the apparent void ratio of the sand skeleton alone, which was generally larger than the void ratios of untreated sand due to the bulking effect of the polymer, resulting in negative relative densities. The calculated void ratios and relative



densities of the sand skeleton fraction, reported in Table 8, indicate the relative consistency between the specimens.

The cement-treated sand specimens were cured for 7 days at room temperature, while the polymer-treated sand specimens were cured for 3 days in an oven at 43 °C (110 °F). Prior to the direct shear tests, the mass, diameter, and height of each specimen were measured at three different locations, and the load cell and position indicators were zeroed. The horizontal shearing rate was set to 0.01in/min, and normal stress values of 5, 10, 20, and 30 psi were selected for each group of specimens. The nominal vertical and shear stresses, vertical displacement, and horizontal shearing displacement were recorded during the direct shear tests. The cohesion and friction angle of the materials were then determined from plots of the peak shear stress versus normal stress, as discussed in Chapter 4.

**Table 7. Actual measured dimensions, total mass, and bulk unit weight for the polymer-amended specimens after curing.**

Sample name	Normal stress	H (inch)	m (g)	V (ft <sup>3</sup> )	Y (pcf)
<b>G54</b>	5 psi	1.036	123.63	0.00294	92.61
<b>2%</b>	20 psi	1.000	120.20	0.00284	93.29
	rebond	1.064	121.64	0.00302	88.72
	30 psi	1.040	124.85	0.00295	93.17
<b>Batch 2 G54</b>					
<b>4%</b>	10 psi	1.020	124.50	0.00290	94.73
	20 psi	1.057	129.00	0.00300	94.72
	30 psi	1.075	132.46	0.00305	95.63
<b>G101</b>					
<b>2% trial 1</b>	10 psi	1.070	130.98	0.00304	95.00
	20 psi	1.054	129.90	0.00299	95.65
	30 psi	1.053	130.02	0.00299	95.83
<b>2% trial 2</b>	10 psi	1.067	129.83	0.00303	94.43
	20 psi	1.100	131.72	0.00312	92.93
	30 psi	1.063	130.76	0.00302	95.47
<b>G101</b>					
<b>4% trial 1</b>	10 psi	1.053	126.44	0.00299	93.19
	20 psi	1.072	135.22	0.00305	97.89
	30 psi	1.064	132.49	0.00302	96.64
<b>4% trial 2</b>	10 psi	1.068	135.00	0.00303	98.15
	20 psi	1.057	133.36	0.00300	97.96
	30 psi	1.031	129.63	0.00293	97.63
<b>cement</b>					
<b>12%</b>	10 psi	1.050	142.65	0.00298	105.44
	20 psi	1.052	141.50	0.00299	104.39
	30 psi	1.047	140.20	0.00297	103.92

**Table 8. Dimensions of cured polymer-amended specimens, and estimated dry unit weight, void ratio, and relative density of the sand fraction.**

Sample name	Normal stress	H (inch)	$m_{\text{sand}}$ (g)	$V(\text{ft}^3)$	$\gamma_{d, \text{sand}}$ (pcf)	$e_{\text{sand}}$	$D_{r, \text{sand}}$ (%)
<b>G54</b>	5 psi	1.036	121.16	0.00294	90.76	0.822	-33.3%
<b>2%</b>	20 psi	1.000	122.35	0.00284	91.42	0.809	-27.8%
	rebond	1.064	119.21	0.00302	86.95	0.902	-66.6%
	30 psi	1.040	117.80	0.00295	91.30	0.811	-28.8%
<b>Batch 2 G54</b>							
<b>4%</b>	10 psi	1.020	119.52	0.00290	90.94	0.818	-31.8%
	20 psi	1.057	123.84	0.00300	90.93	0.819	-31.9%
	30 psi	1.075	127.16	0.00305	91.80	0.801	-24.7%
<b>G101</b>							
<b>2% trial 1</b>	10 psi	1.070	128.36	0.00304	93.10	0.776	-14.2%
	20 psi	1.054	127.30	0.00299	93.74	0.764	-9.2%
	30 psi	1.053	127.42	0.00299	93.91	0.761	-7.8%
<b>2% trial 2</b>	10 psi	1.067	127.23	0.00303	92.54	0.787	-18.7%
	20 psi	1.100	129.09	0.00312	91.07	0.816	-30.7%
	30 psi	1.063	128.14	0.00302	93.56	0.767	-10.6%
<b>G101</b>							
<b>4% trial 1</b>	10 psi	1.053	121.38	0.00299	89.46	0.848	-44.3%
	20 psi	1.072	129.81	0.00305	93.98	0.760	-7.3%
	30 psi	1.064	127.19	0.00302	92.77	0.782	-16.8%
<b>4% trial 2</b>	10 psi	1.068	129.60	0.00303	94.22	0.755	-5.4%
	20 psi	1.057	128.03	0.00300	94.04	0.758	-6.8%
	30 psi	1.031	124.44	0.00293	93.72	0.764	-9.3%
<b>cement</b>							
<b>12%</b>	10 psi	1.050	125.53	0.00298	92.78	0.782	-16.8%
	20 psi	1.052	124.52	0.00299	91.86	0.800	-24.2%
	30 psi	1.047	123.38	0.00297	91.45	0.808	-27.6%

## CHAPTER 4. EXPERIMENTAL RESULTS AND DISCUSSION

### Western Iowa Loess

#### Compaction test results

The compaction test results for Western Iowa loess are shown in Figure 21. The compaction curves followed typical textbook bell-shaped trends (e.g., Holtz et al. 2011). The results from the modified 2×4 compaction tests are similar to those from the 2×2 compaction test results, but resulted in slightly lower dry unit weights and a higher optimum moisture content. From the 2×2 results, the optimum moisture content of loess was 17.1% and the corresponding maximum dry unit weight was 105.4 pcf. For the modified 2×4 procedure, the optimum moisture content was 18% and the maximum dry unit weight was 101.9 pcf.

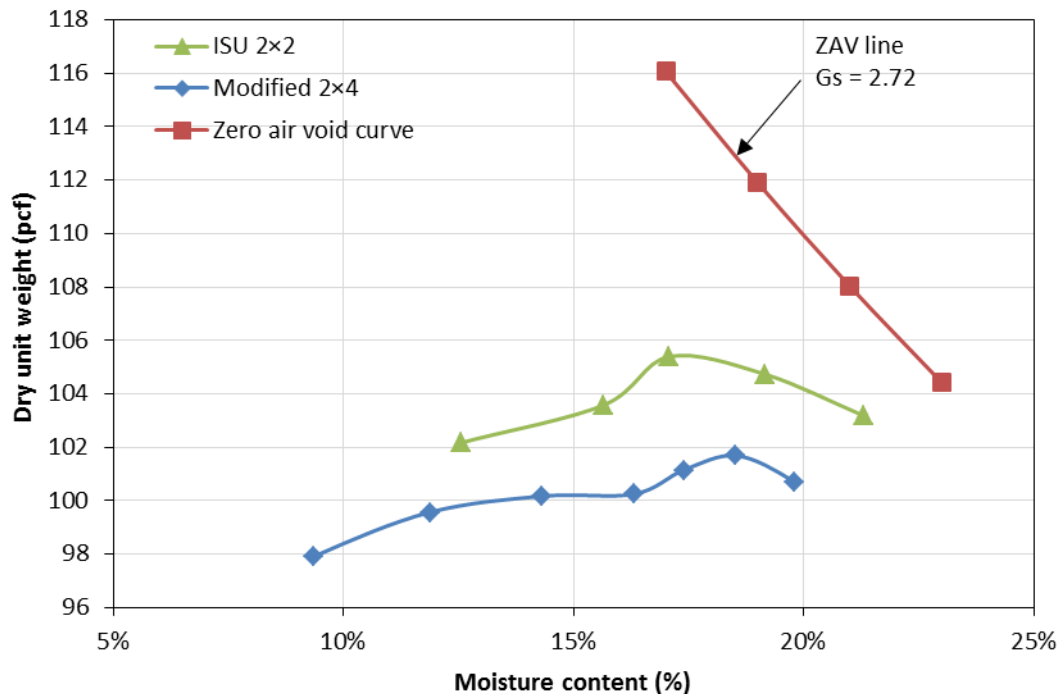
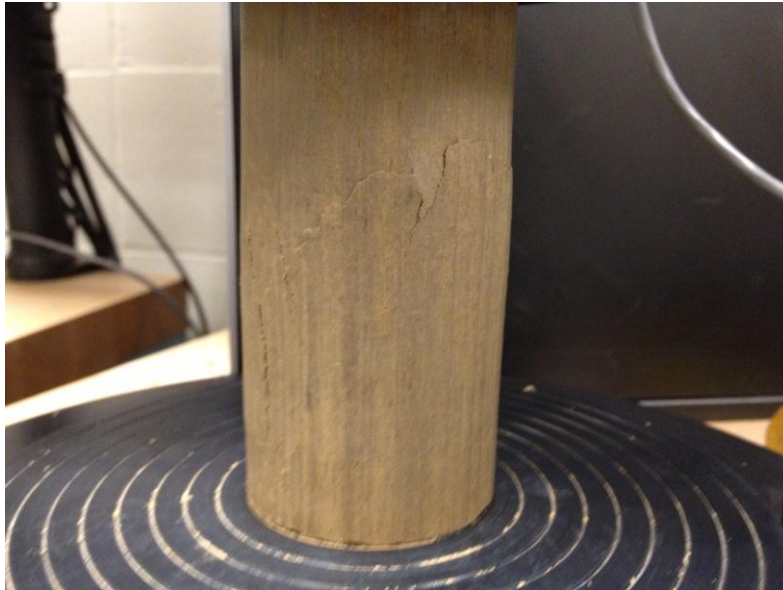


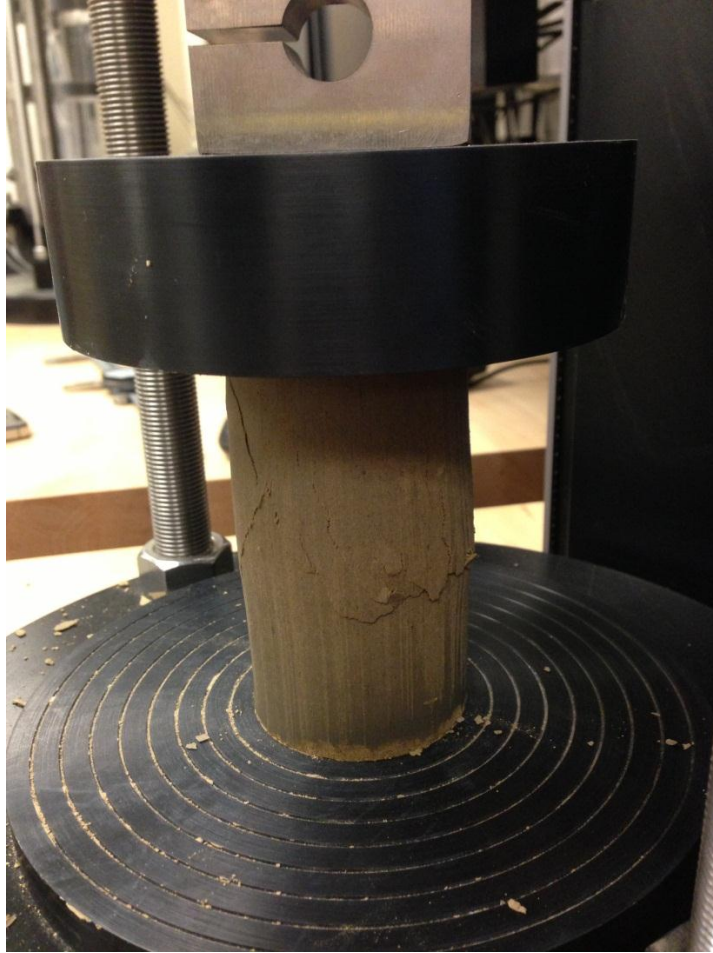
Figure 21. Compaction test results for untreated loess.

### Unconfined compressive strength results

The unconfined compressive strength (UCS) is an engineering property designating the undrained shear strength of cohesive specimens. For stabilized soil specimens, the value of the UCS is affected by the curing method, curing time, stabilizer type, and stabilizer content. In general, UCS is also a function of moisture content and compaction energy. To control the number of variables in this study, and also to measure UCS values that would correspond to field-compaction specifications, all the monomer-treated UC specimens were prepared at the optimum moisture content (OMC) of the untreated 2×4 specimens determined from Figure 21. The UCS of untreated specimens at OMC and 2% below OMC were also measured as a control group for comparison with the amended soils. For the polymer-amended specimens, the water was reduced assuming a 1:1 replacement by polymer. For each polymer content (including 0%), three individual specimens were tested to verify repeatability and obtain statistical average values. Typical failures of the monomer-treated and untreated specimens in unconfined compression tests are shown in Figures 22 and 23.



**Figure 22. Typical failure of monomer-treated specimens in unconfined compression tests.**



**Figure 23. Typical failure of untreated specimens in unconfined compression tests.**

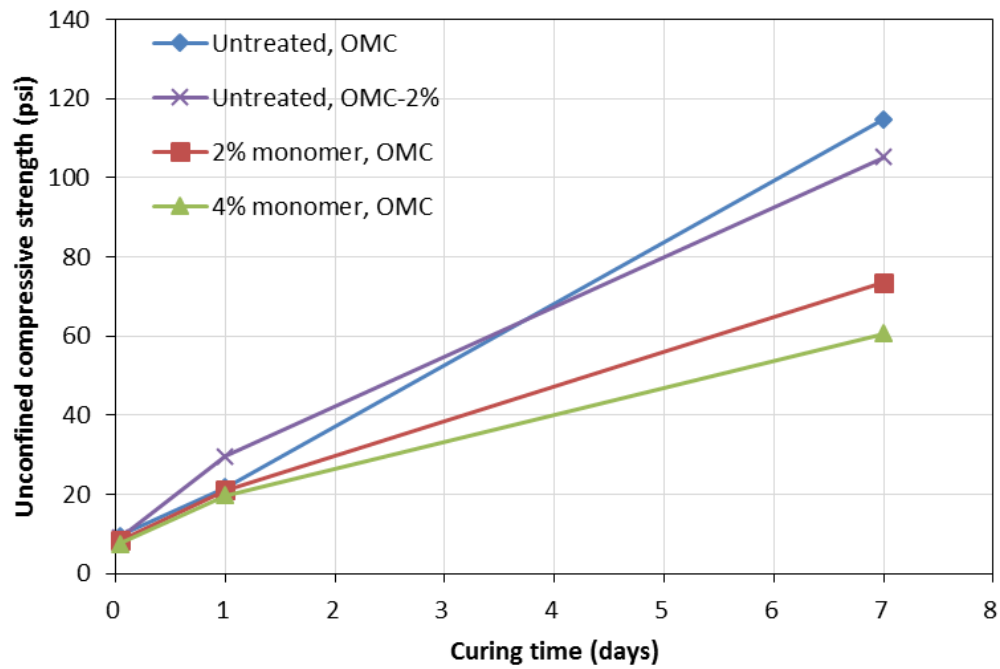
*Effect of curing time and monomer content on UCS*

To examine the influence of curing time on unconfined compressive strength, specimens were prepared and tested with curing times of 0, 1, 7, and 28 days. Test results for 2% and 4% monomer-amended specimens compacted at OMC and untreated loess compacted at OMC and OMC–2% are shown in Table 9 and Figures 24 and 25. All specimens exhibited similar strength values for a curing time of 1 day, and the strengths of the untreated specimens increased more rapidly with time than the monomer-stabilized specimens (Figure 24). However, beyond 7 days of curing, the strength of the 2% monomer-stabilized loess specimens continued to increase more rapidly, and eventually exceeded that of the untreated OMC–2% specimens after about 26 days (Figure 25). Finally, the average UCS of

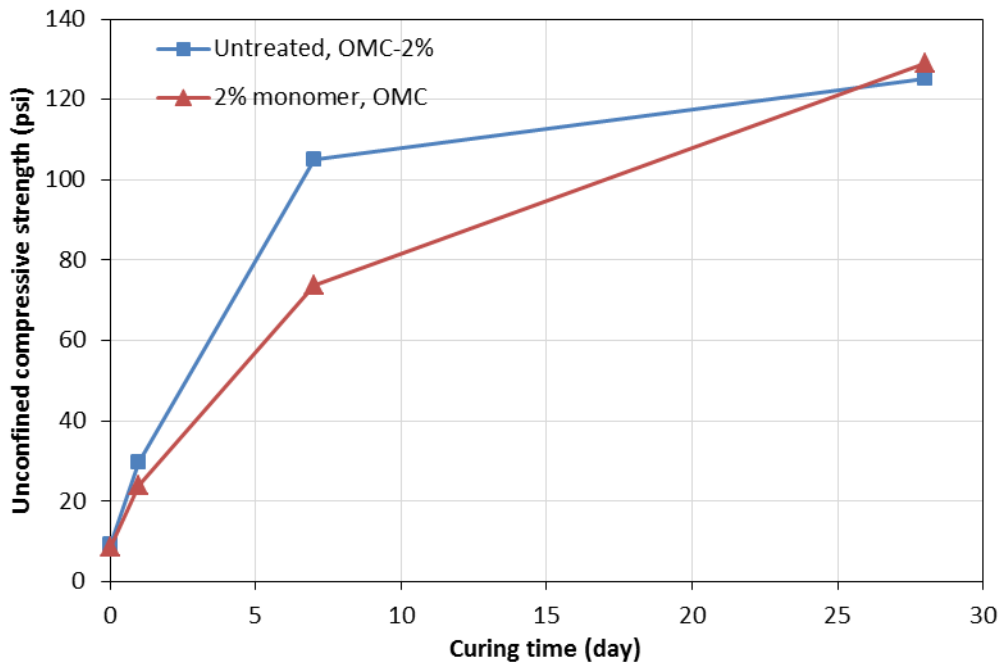
specimens with 2% monomer became slightly greater than that of the untreated OMC–2% specimens after 28 days of curing. Two out of three trials for the 2% monomer-amended specimens had strengths approximately 20% greater than the untreated loess. It is possible that the first trial with a low strength may be an outlier due to a problem with sample preparation. Thus, it appears that a strength increase of monomer-amended loess may occur due to sufficient aging of the polymer or evaporation of sufficient water from the sample. Although the average 28-day strength of the 2% monomer-stabilized specimens is slightly larger than that of the untreated OMC–2% specimens, it is still much lower than that of cement-stabilized loess, which can reach values as high as 246 psi as reported Angelova (2007).

**Table 9. Unconfined compressive strength results for monomer-treated loess specimens.**

Curing time (day)	Trial	Unconfined compressive strength (psi)			
		OMC			OMC-2%
		Monomer Content (%)			
		0	2	4	0
0	1	9.8	8.2	7.3	9.5
	2	9.5	8.8	7.2	9.0
	3	9.5	8.4	8.2	8.9
Mean		9.6	8.5	7.6	9.1
Standard deviation		0.2	0.3	0.6	0.3
1	1	21.5	15.6	19.8	24.7
	2	20.8	24.8	20.7	27.0
	3	23.1	22.9	18.8	37.3
Mean		21.8	21.1	19.7	29.7
Standard deviation		1.2	4.9	1.0	6.7
7	1	64.1	68.1	36.2	98.4
	2	114.8	46.4	58.8	116.6
	3	82.0	79.1	62.7	100.6
Mean		86.9	64.5	52.6	105.2
Standard deviation		25.7	16.6	14.3	9.9
28	1	-	80.1	-	119.1
	2	-	158.3	-	120.1
	3	-	148.1	-	136.3
Mean		-	128.8	-	125.1
Standard deviation		-	42.5	-	9.6



**Figure 24. Effect of curing time up to 7 days on average UCS of untreated and monomer-amended loess specimens.**

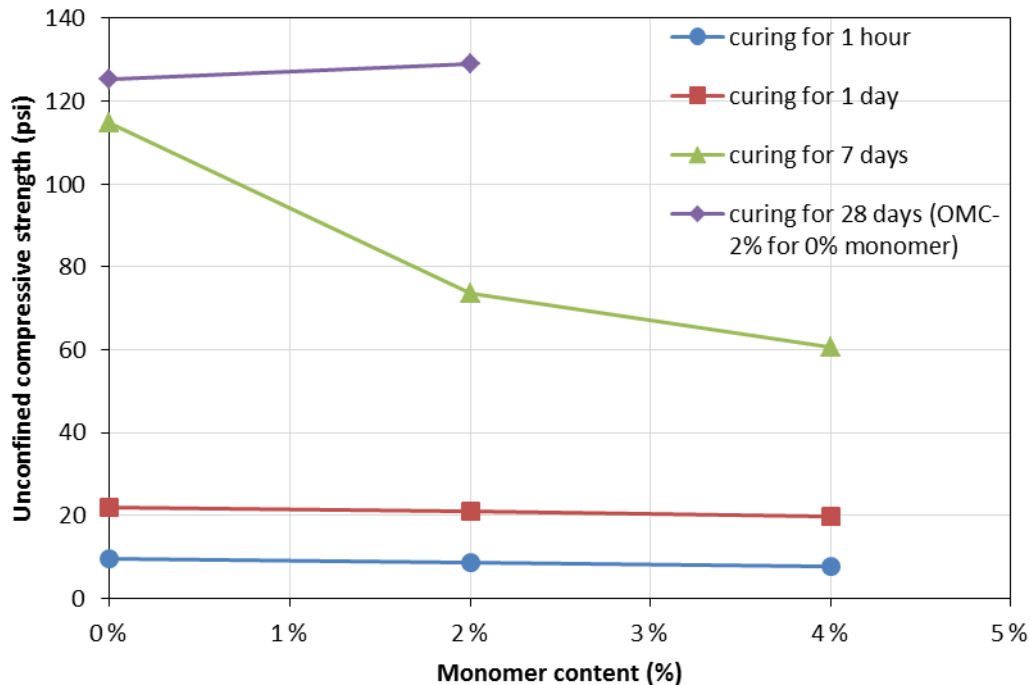


**Figure 25. Effect of curing time up to 28 days on average UCS of untreated and monomer-amended loess specimens.**



Effect of monomer content on UCS of loess specimens

The relationship between monomer content and unconfined compressive strength is presented in Figure 26. For curing times of 1 hour and 1 day, the strength of the untreated loess was virtually unaffected by the monomer content. The strength at 7 days was decreased by 35% and 48% for 2% and 4% monomer contents, respectively. However, a slight strength increase of 3% over that of the untreated OMC-2% specimen was observed for the 2% monomer specimen at 28 days, with Trials 2 and 3 having shear strengths roughly 20% higher than the untreated loess.



**Figure 26. Effect of monomer content and curing time on average UCS of loess specimens compacted at OMC.**

Effect of polymer content on stress-strain behavior

In addition to its effect on strength, another anticipated potential benefit of polymer stabilization is to change the stress-strain behavior from a brittle failure to one that is more ductile. Increased ductility would enable soils and slopes to undergo larger deformations

before failure. Additionally, failures would occur more gradually with time rather than suddenly, giving engineers more time to notice and react. To investigate this aspect, the stress-strain curves from UC tests on the loess specimens are shown in Figures 27 through 30. All curves exhibit an initial quasi-linear region followed by a strain-softening yield zone characteristic of dense specimens. Based on these plots, the stiffness (slope) and failure modes indicated by the stress-strain curves for monomer-stabilized loess are very similar to those of the untreated loess for curing durations of 1 hour and 1 day (Figures 27 and 28). For a curing duration of 7 days, however, the stiffness of the stress-strain curve for the untreated specimen is initially lower, but eventually exceeds those of the monomer-stabilized specimens, whereas the strength of the untreated specimen is greater than that of the monomer-stabilized specimens (Figure 29). The monomer-amended specimens showed a slight increase in ductility relative to the untreated specimen after 1 hour of curing, but lower ductility after 1 day and 7 days of curing. Thus, the amended loess did not exhibit an increase in stiffness, ductility, or strength in the first 7 days of curing.

At first glance, these findings appear to support the statement by Newman and Tingle (2004) that “Previous research studies in this area have demonstrated that many soil additives have little to no benefit for silty, sandy soil types.” However, a limited number of tests were conducted after 28 days of curing, for which an increase in strength was observed for some of the monomer-treated specimens (Table 9 and Figure 30). This indicates that further testing of longer curing times as well as refinement of the monomer’s physical and chemical properties may yet prove beneficial for improving the strength of loess soils.

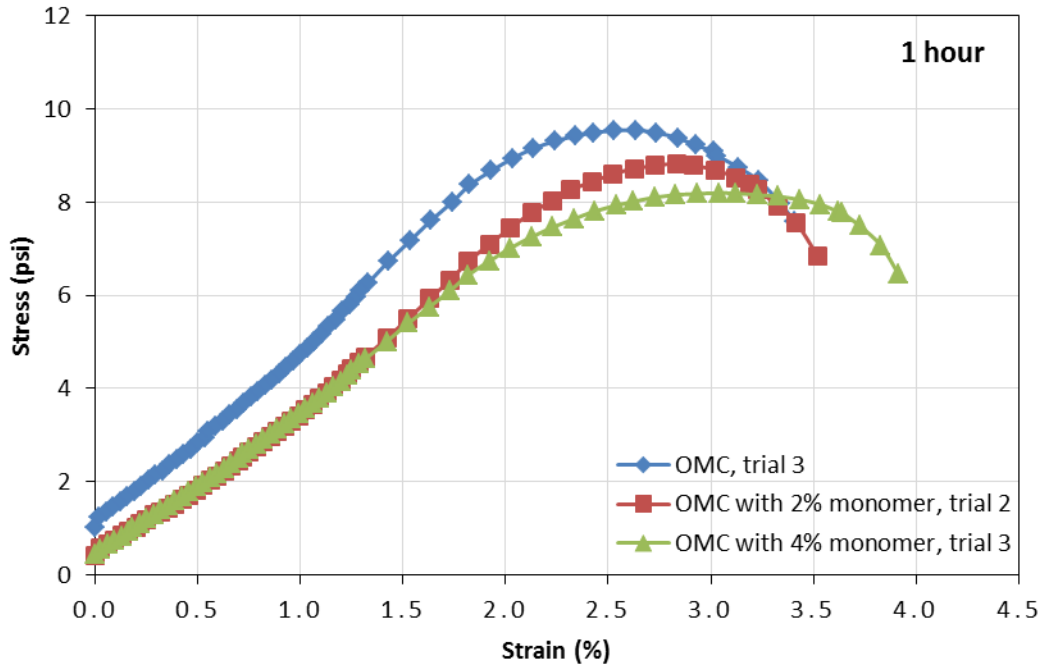


Figure 27. Effect of monomer content on UC stress-strain response of loess for curing time of 1 hour.

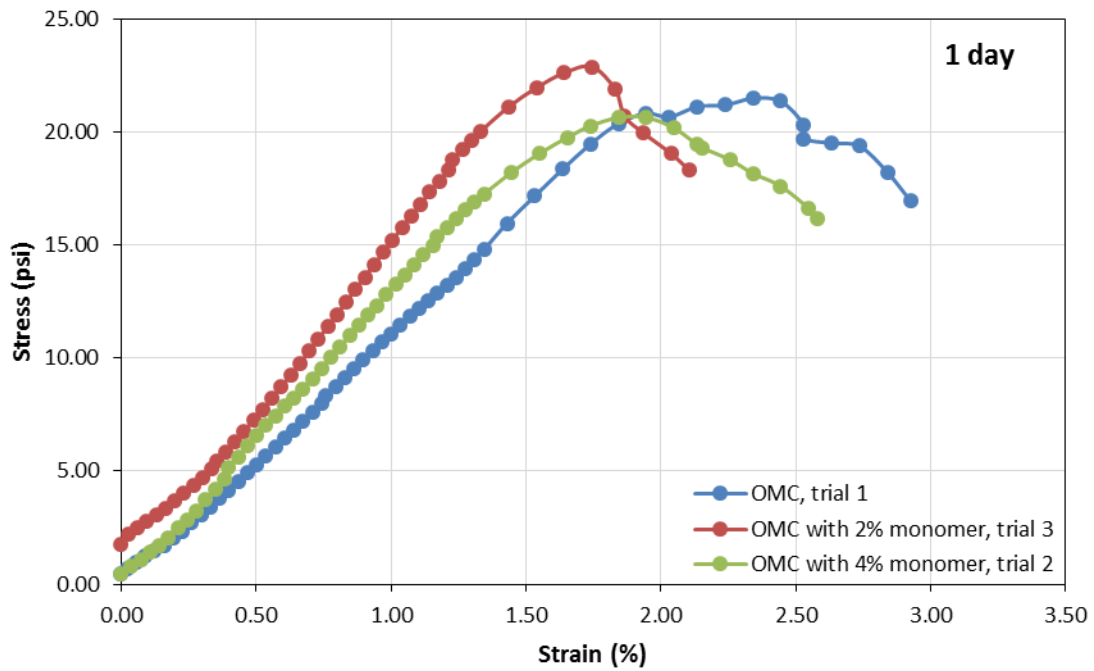
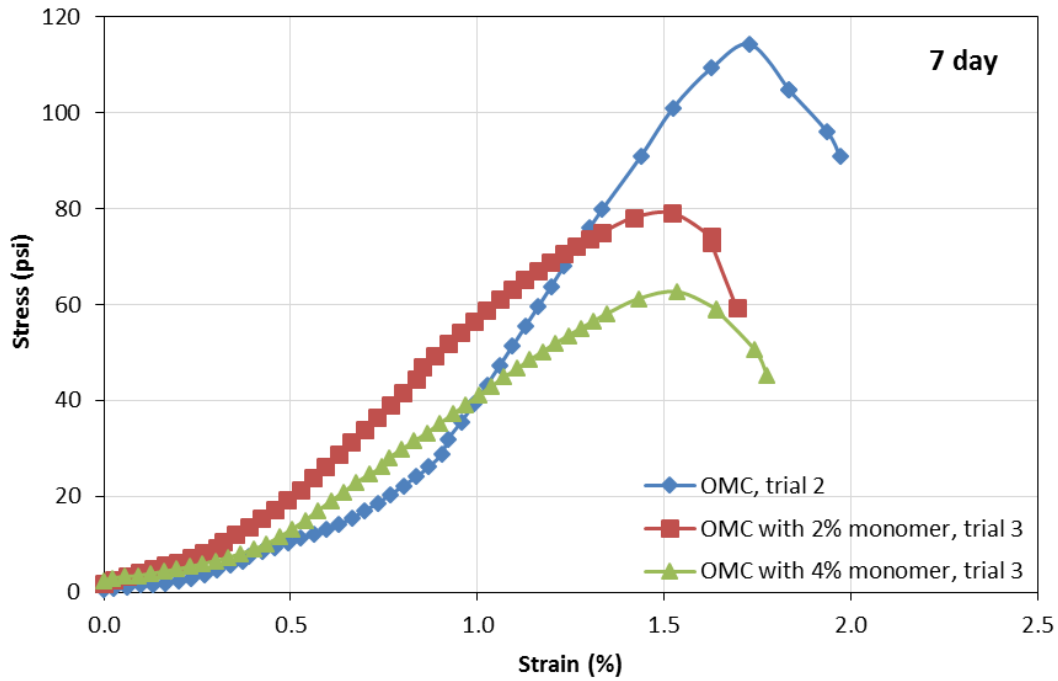
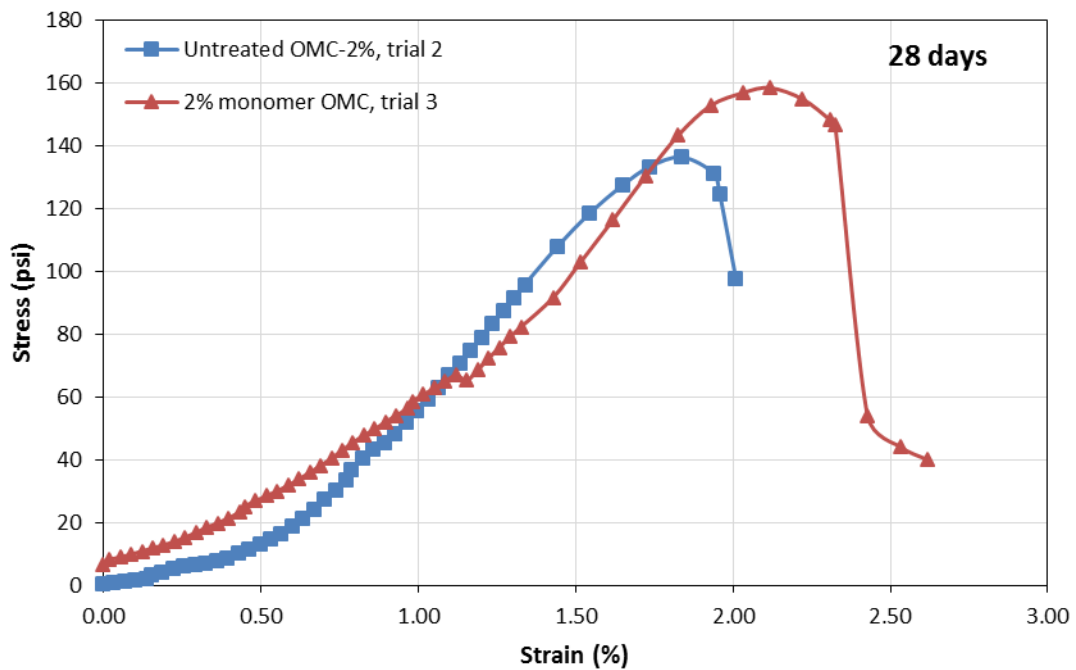


Figure 28. Effect of monomer content on UC stress-strain response of loess for curing time of 1 day.



**Figure 29. Effect of monomer content on UC stress-strain response of loess for curing time of 7 days.**



**Figure 30. Effect of monomer content on UC stress-strain response of loess for curing time of 28 days.**

### **Ottawa sand**

As noted by Newman and Tingle (2004), “Sandy soils are problematic for stabilization and often require cement and/or asphalt emulsion to provide cohesion for the soil.” Therefore, bio-polymers derived from plant materials such as those investigated in this research could offer more environmentally friendly and sustainable alternatives to cement and asphalt for soil stabilization. The use of cement or petroleum-based stabilizers consumes finite natural resources, whereas bio-polymers are created from renewable plant-based feed stocks. Additionally, processing of cement and asphalt consumes large amounts of energy while generating significant amounts of CO<sub>2</sub> and other greenhouse gasses, whereas production of bio-polymers may require relatively less energy.

As an example, one possible application of bio-polymer stabilization of saturated sandy soils is to improve their resistance to liquefaction following earthquakes. Liquefaction is the loss of strength of saturated sandy soils due to increase in pore water pressure during cyclic shearing, which can be responsible for loss of life and damage to infrastructure on every continent amounting to several hundred billion U.S. dollars for large earthquakes. For mitigation of liquefaction potential, a stabilizer should impart some cohesion to the sand, while at the same time resisting loss of strength due to increasing pore water pressure during shaking. This also requires that the stabilization method be “waterproof”. Ideally, if the cohesive bonds are broken due to strong shaking or large static stresses, it would be beneficial if the sand could heal and regain cohesive strength as well.

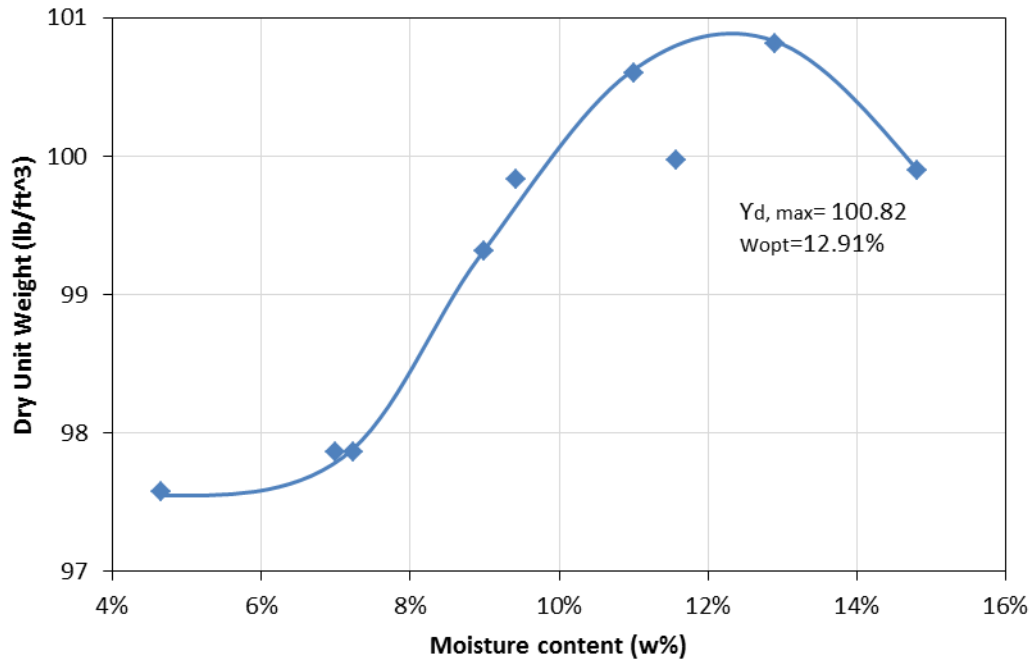
As a first step to investigate the stabilization potential of the bio-polymers studied herein, the drained shear strength of biopolymer-stabilized sand specimens was measured using direct shear (DS) tests. The DS tests enabled the cohesion and friction angle of the

specimens to be measured. If the polymers are found to impart cohesion to the sands, then they may be useful for further liquefaction-related tests involving dynamic loading and pore-pressure measurement, such as cyclic triaxial or direct simple shear tests. The healing potential of the polymers was also investigated by re-testing previously sheared specimens several days after their first DS test. Resistance to water was also studied by immersing specimens in water and observing whether they stayed intact.

### **Compaction test results**

The compaction test results for Ottawa 20-30 sand are shown in Figure 31. The optimum moisture content for Ottawa sand was determined to be 13%, and all the specimens used for subsequent direct shear tests were prepared with moisture contents 2% below the optimum. For reference, Homauoni et al. (2011) presented compaction test results for dune sand, also classified in the SP group according to the USCS. The optimum moisture content of dune sand from their study was also found to be about 13%.

Since the permeability of sand is relatively high, some of the water drains and is lost during the compaction tests. Therefore, some data points from the standard compaction test for Ottawa sand may not be accurate, so more data points were added to produce an accurate compaction curve.



**Figure 31. Compaction test results for Ottawa sand.**

### Direct shear test results

Results from all direct shear tests performed on Ottawa sand specimens are presented in this section. In addition to polymer-stabilized sand specimens, untreated and traditional cement-stabilized specimens were also tested as control groups used for comparison. As noted in Chapter 3, all cement-treated sand specimens were cured for 7 days at room temperature, while all polymer-treated sand specimens were cured for 3 days in an oven at 43 °C (110 °F). Both the cement- and polymer-amended Ottawa 20/30 sand specimens showed improved shear-strength properties. Effects of aging and the healing properties of the polymer-amended samples are also described in this section.

The typical direct shear failure characteristics of cement-amended sand specimens is shown in Figure 32, while those of 2% and 4% polymer-amended sand specimens are shown in Figures 33 and 34. For a polymer content of 2% as well as cement contents of 8% and

12%, the specimens were completely fractured by shearing into two separate intact halves that remained cemented (Figures 32 and 33), indicating a more brittle failure. For a polymer content of 4%, the top half was displaced relative to the bottom, but the two parts of the specimen remained bonded by the polymer, indicating a more ductile failure and a polymer cementation with a capacity for large shearing displacements (Figure 34).



**Figure 32. 8% cement-amended sand specimen after failure.**





**Figure 33. 2% polymer-amended sand specimen after failure.**



**Figure 34. 4% polymer-amended sand specimen after failure.**

*Shear stress and volume change behavior in direct shear tests*

Figures 35 through 68 show the direct shear data for all of the polymer-amended, cement-amended, and untreated Ottawa sand specimens. For each group of tests, both the shear stress and vertical displacement are plotted as functions of horizontal displacement for the different applied normal stresses. All of the vertical displacement data show an initial slight contraction followed by a larger increase in sample volume (dilation) during shearing, which is characteristic of dense sands. The peak shear stresses generally occur where the slopes of the vertical displacement vs. horizontal displacement curves reach their maximum values.

The polymer-amended sand specimens all exhibited greater peak shear stresses and larger volume expansions than those of untreated sand. Comparing the polymer-amended to cement-amended sand, the peak shear stresses of the polymer-amended sands showed values close to those of the 8% cement-amended specimens. The 12% cement-stabilized sand exhibited the greatest strength increase compared to the other series.

From Figures 35 through 68, it can be observed that polymer content is a very important factor controlling the amount of volume expansion. With increasing polymer content, the slopes of the shear stress versus horizontal displacement curves generally decreased, while the volume expansion increased. The polymer also modified the brittle failure behavior of the sand, making it more ductile; increasing polymer content generally produced larger displacements at the peaks, with a more gradual reduction in post-peak shear stress under increasing displacement.

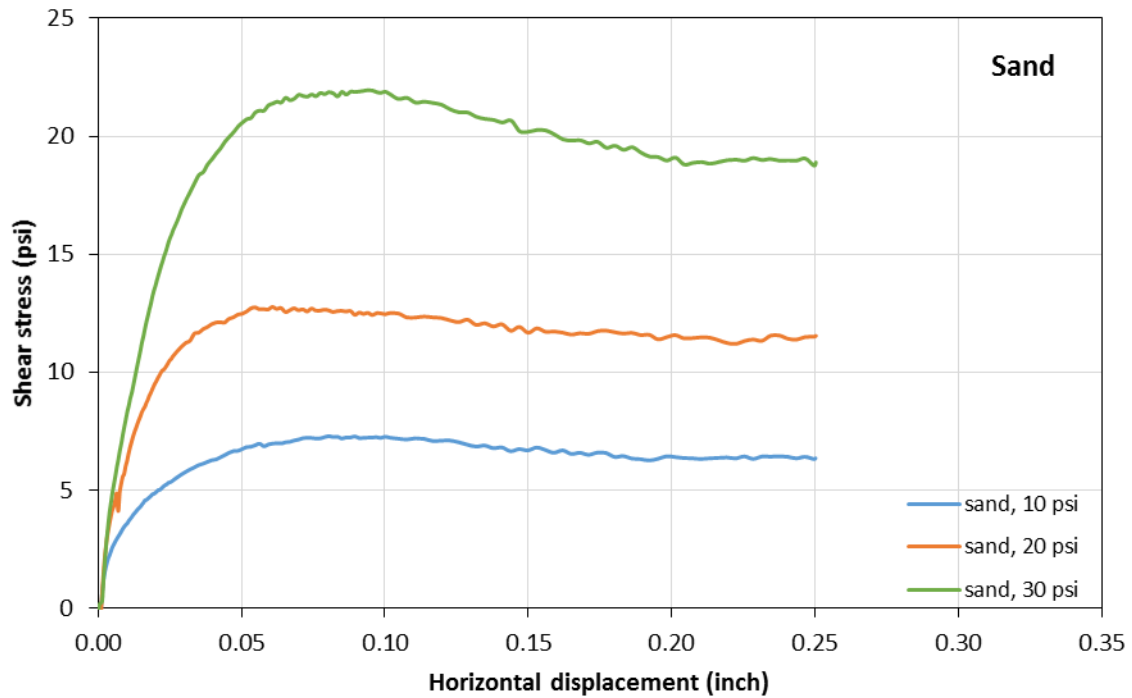


Figure 35. Shear stress versus horizontal displacement for untreated Ottawa 20/30 sand.

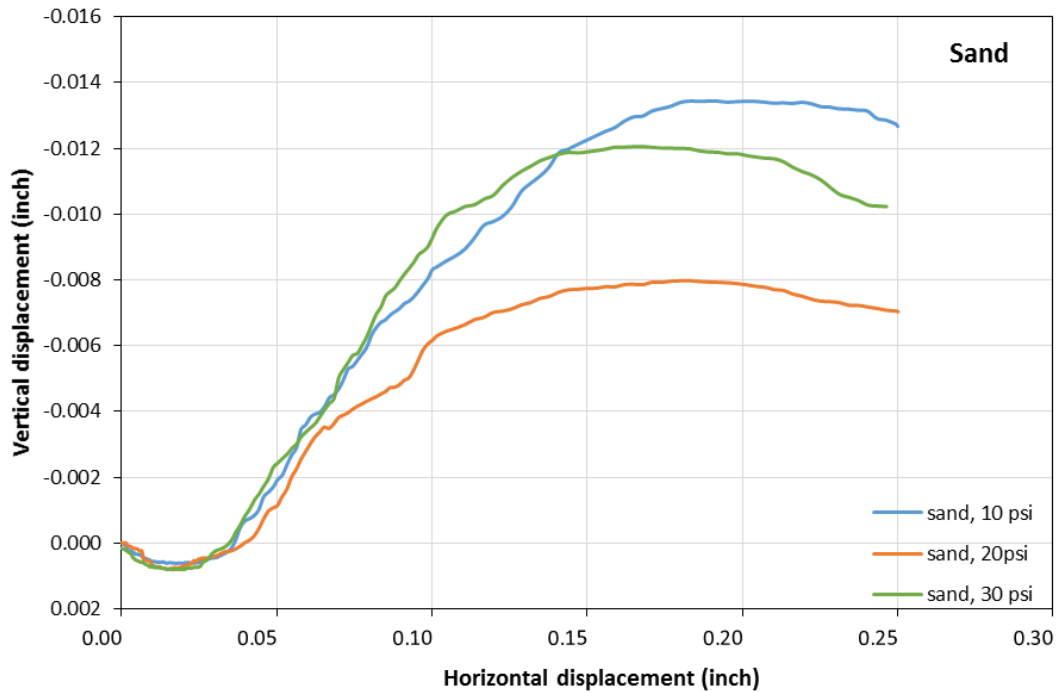


Figure 36. Vertical displacement versus horizontal displacement for untreated Ottawa 20/30 sand.

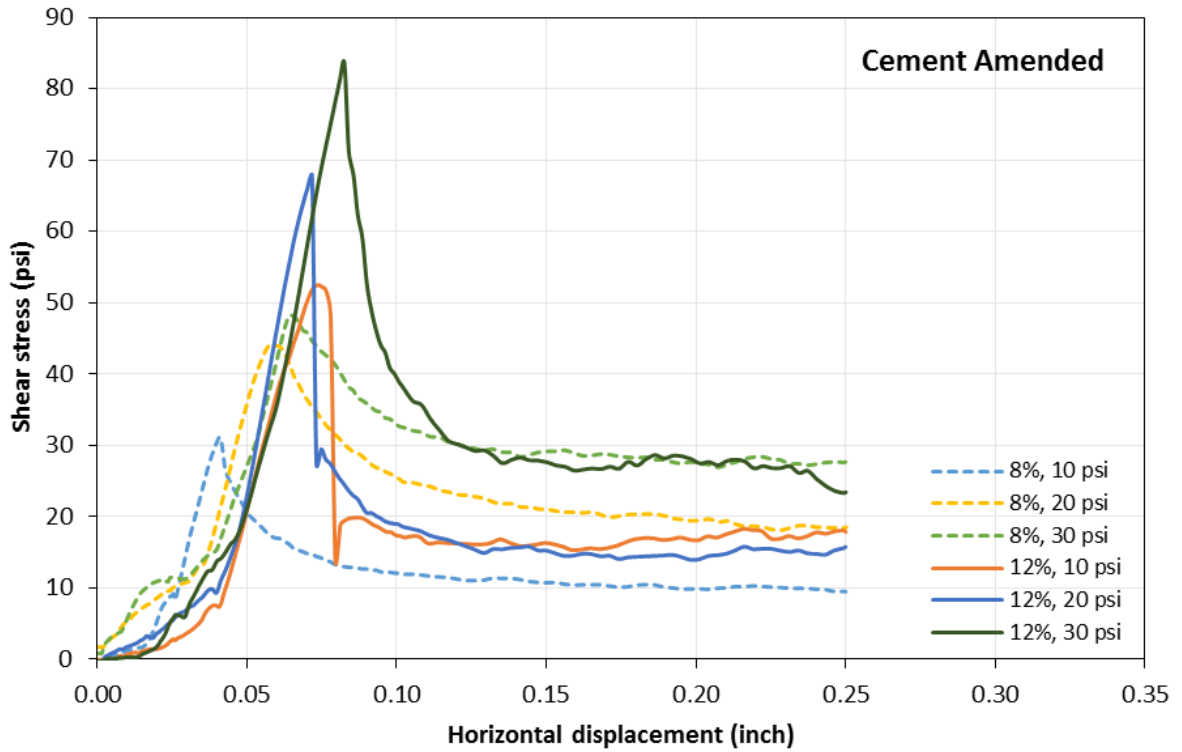


Figure 37. Shear stress versus horizontal displacement for cement-amended sand.

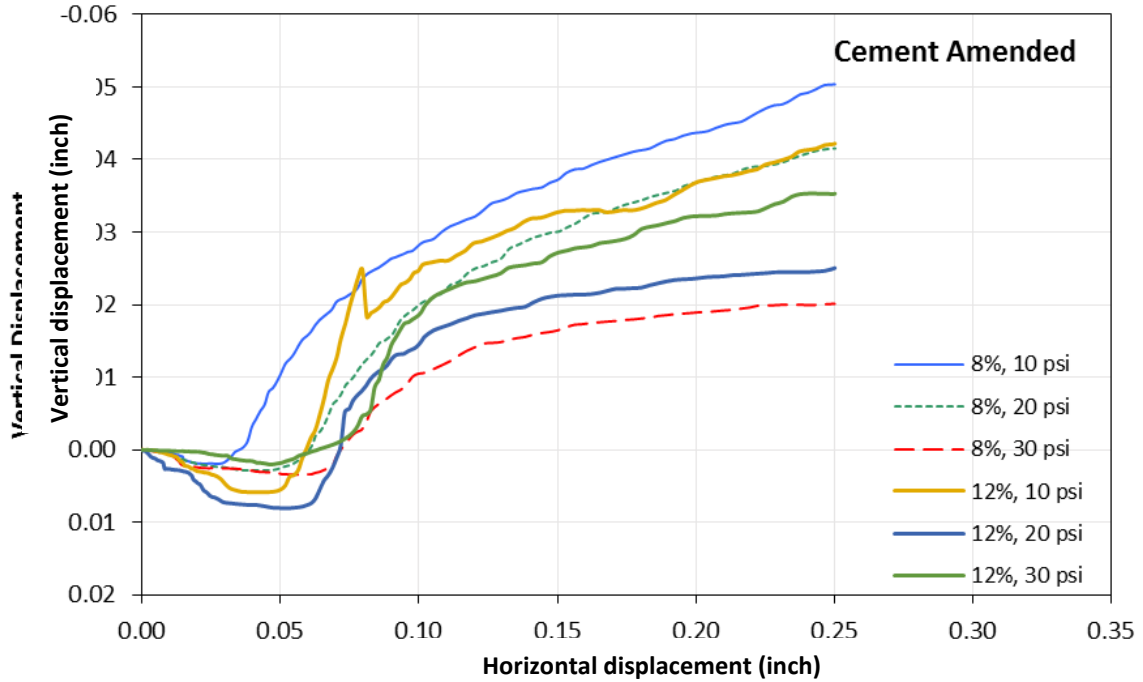


Figure 38. Vertical displacement versus horizontal displacement for cement-amended sand.

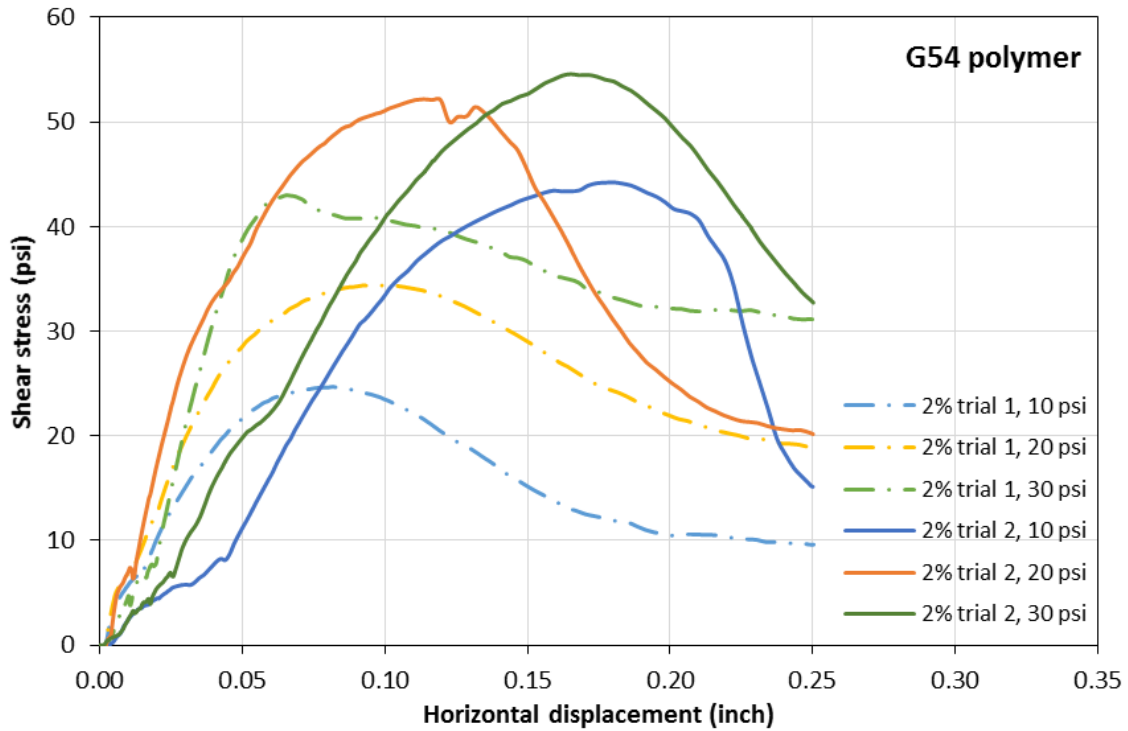


Figure 39. Shear stress versus horizontal displacement for G54 polymer-amended sand.

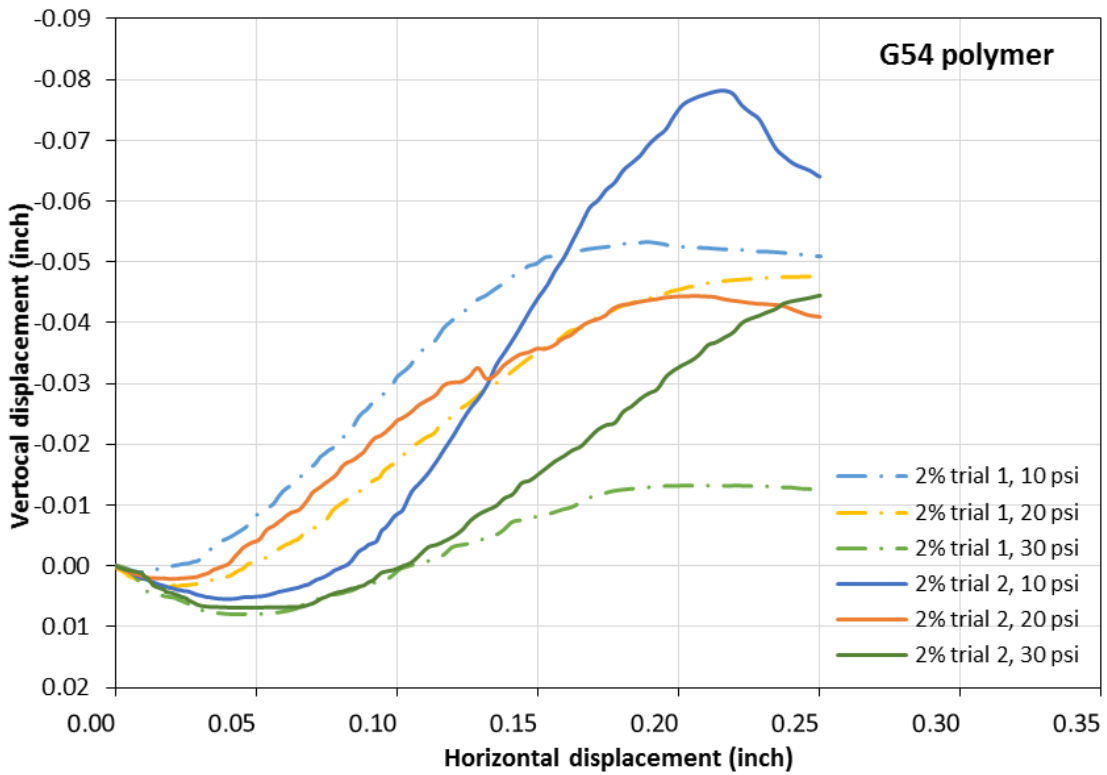
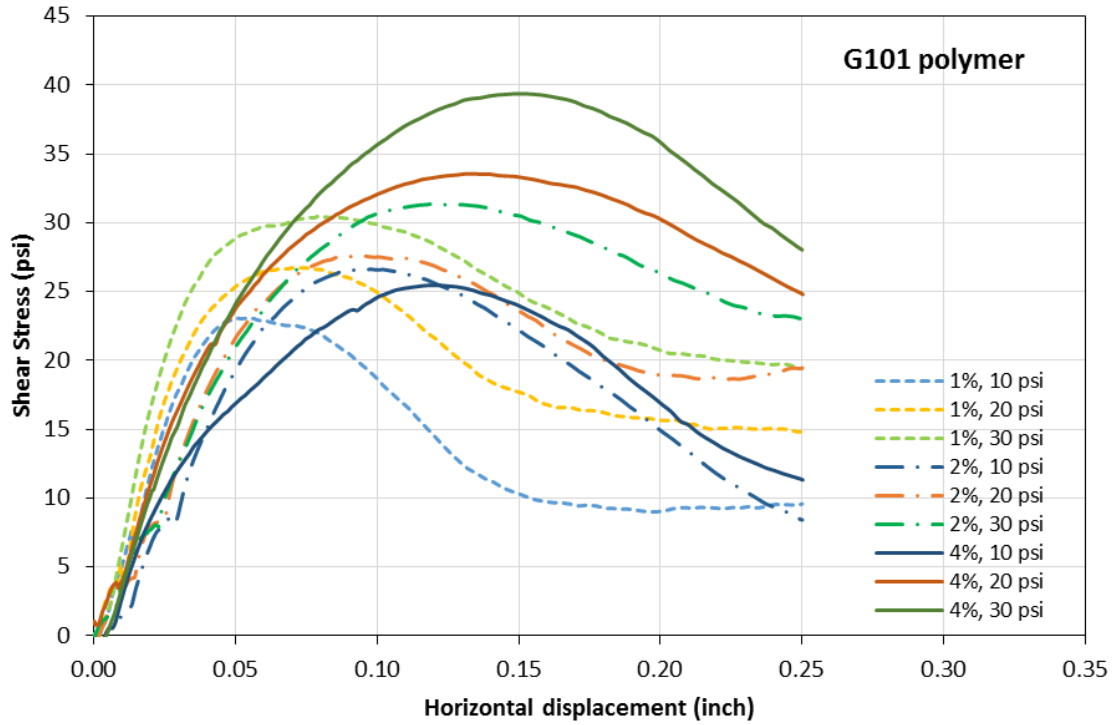
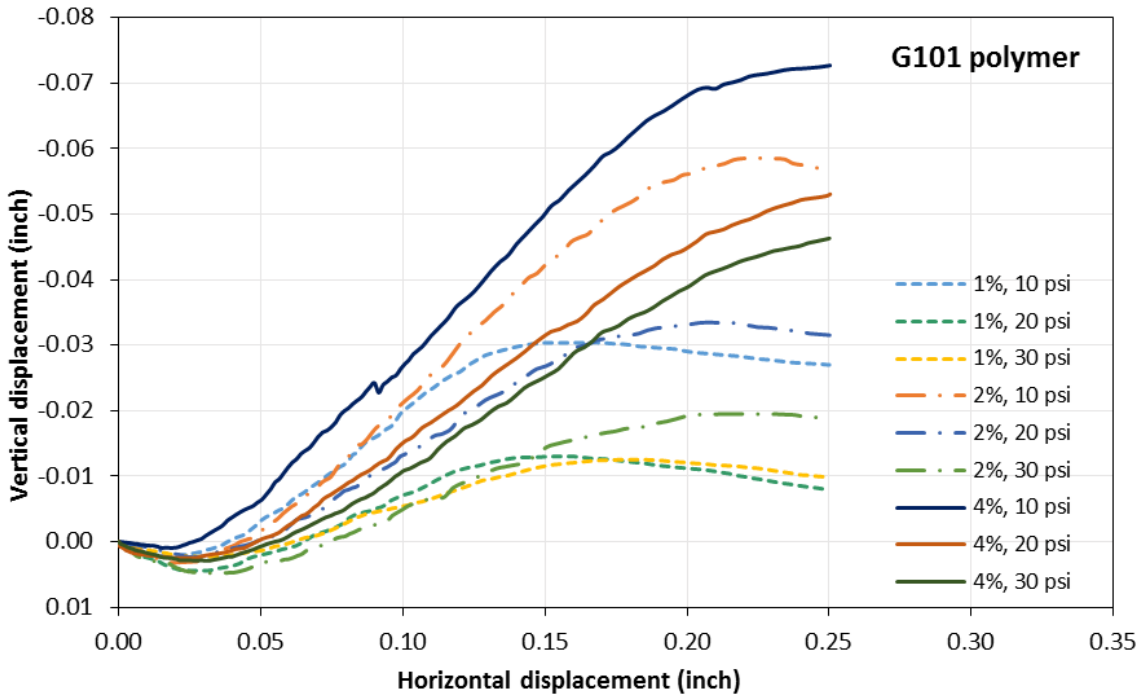


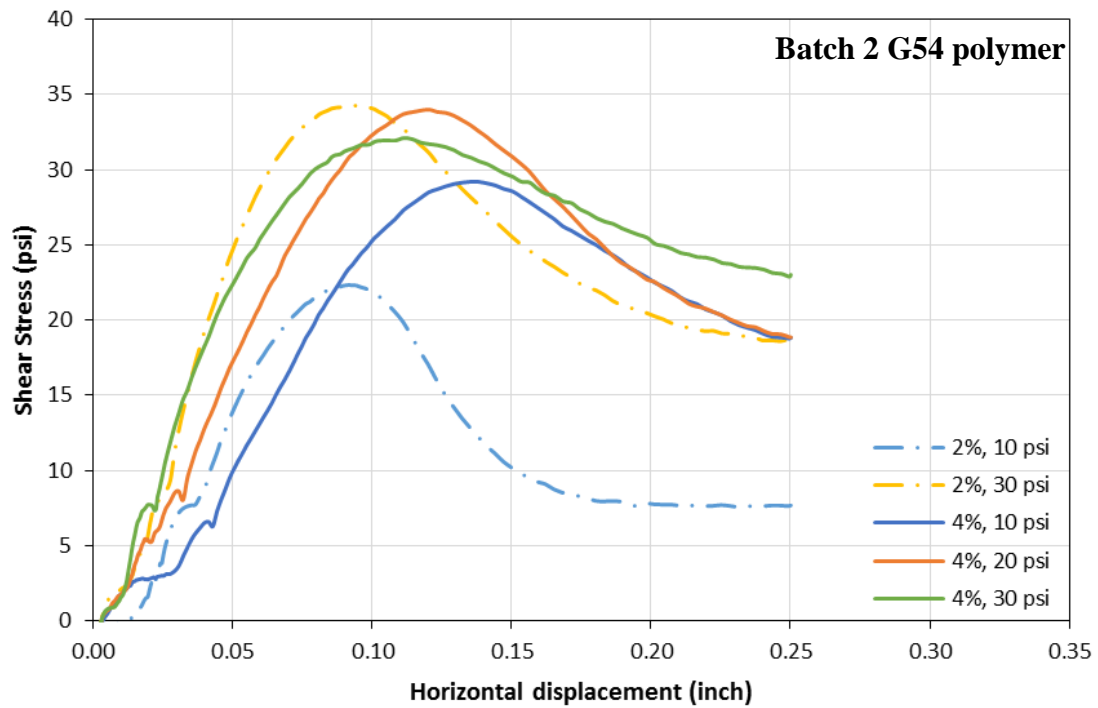
Figure 40. Vertical displacement versus horizontal displacement for G54 polymer-amended sand.



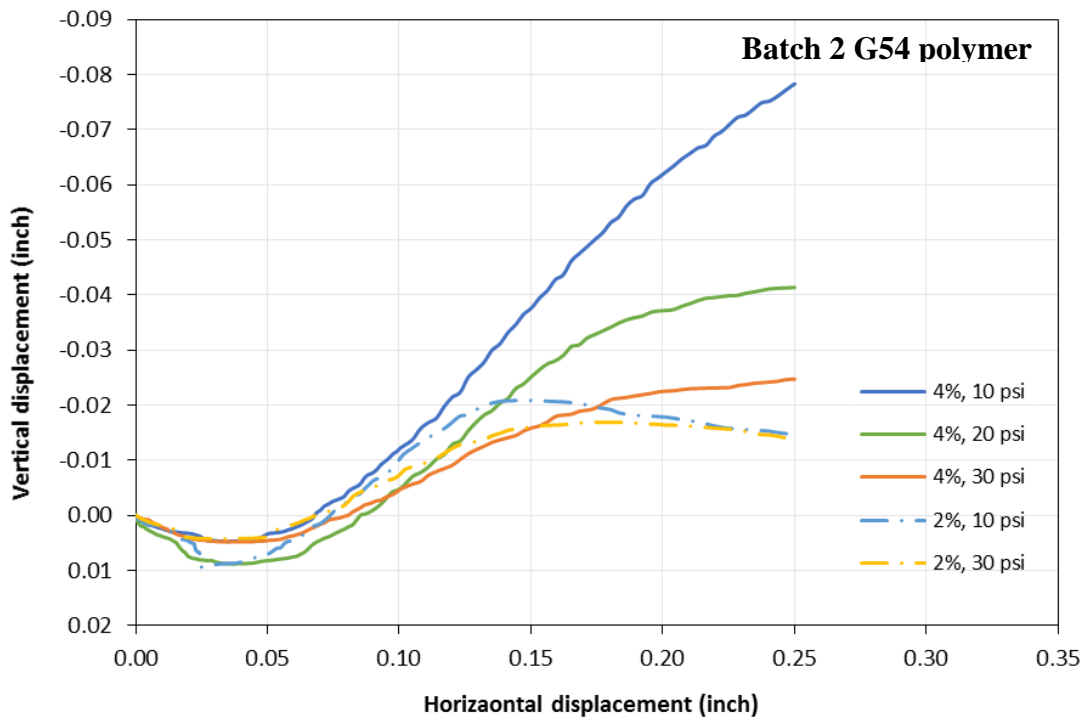
**Figure 41. Shear stress versus horizontal displacement for G101 polymer-amended sand.**



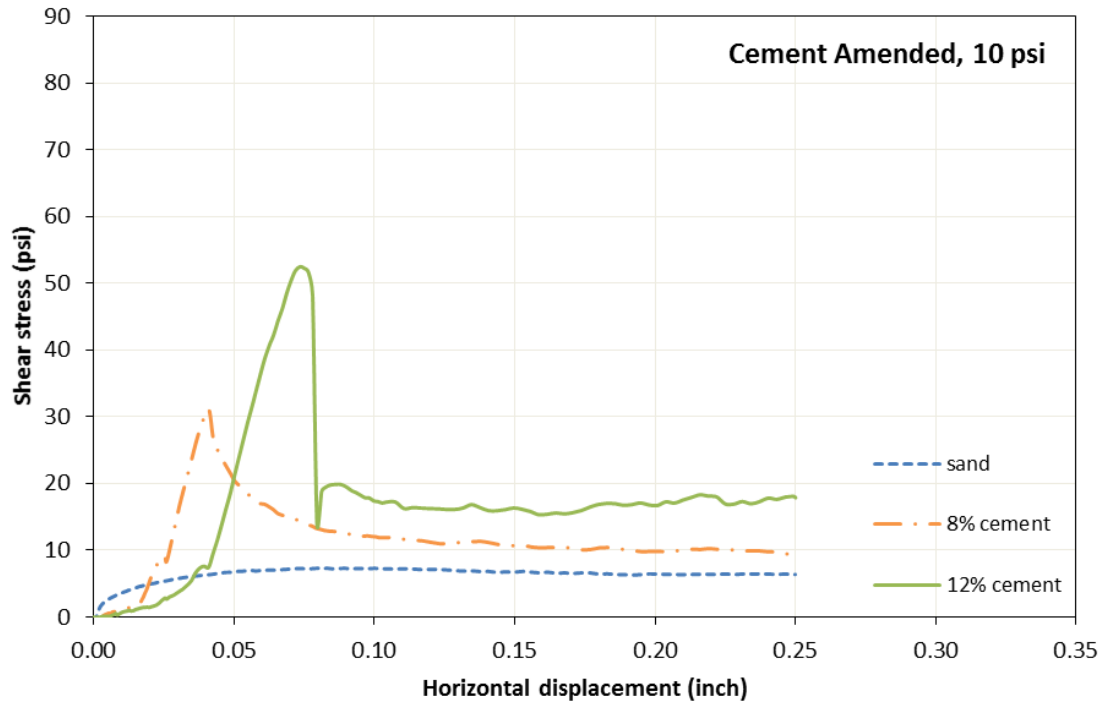
**Figure 42. Vertical displacement versus horizontal displacement for G101 polymer-amended sand.**



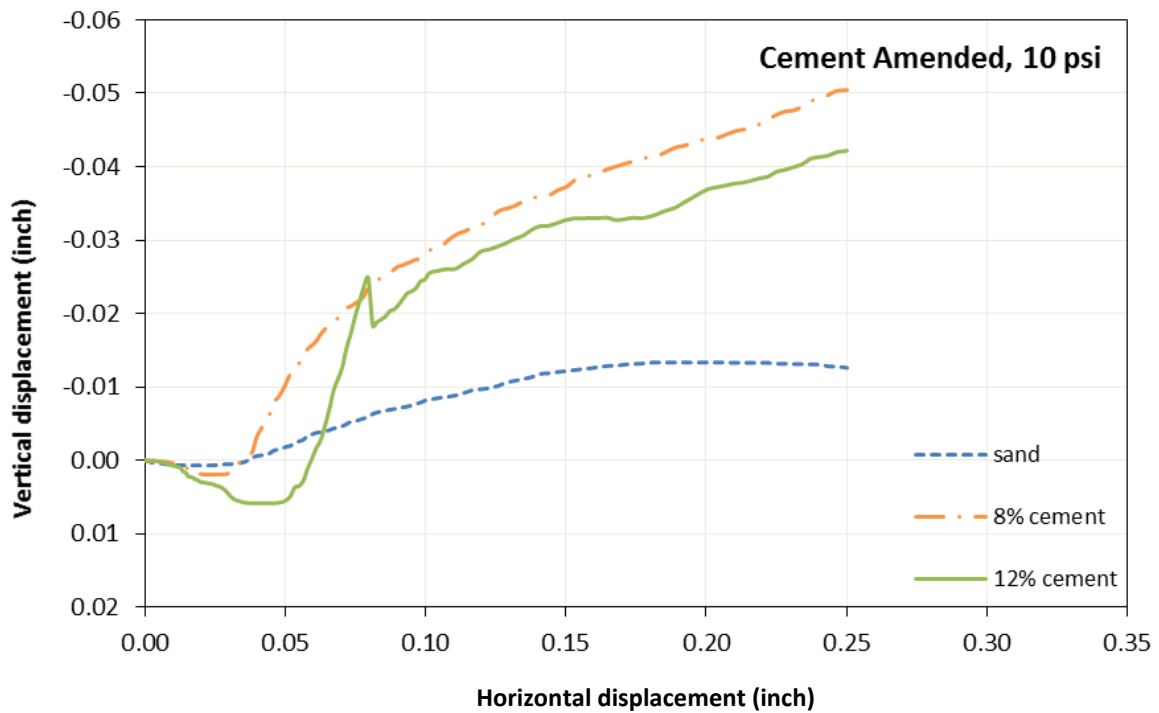
**Figure 43. Shear stress versus horizontal displacement for Batch 2 G54 polymer-amended sand.**



**Figure 44. Vertical displacement versus horizontal displacement for Batch 2 G54 polymer-amended sand.**

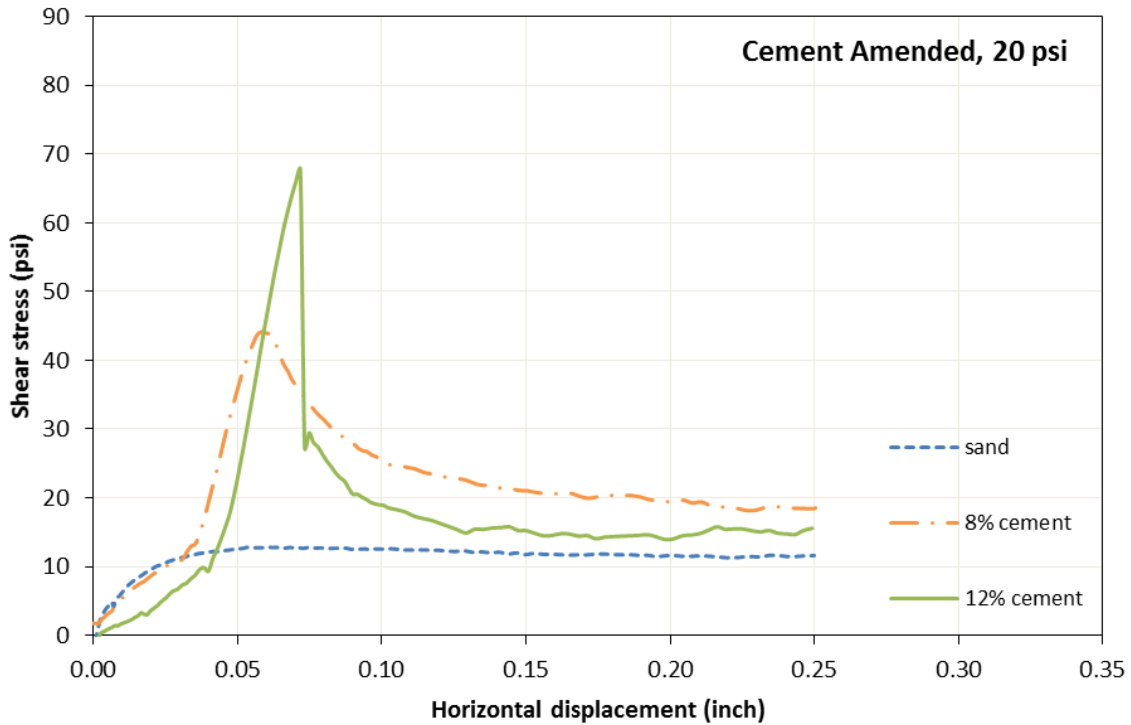


**Figure 45. Shear stress versus horizontal displacement for cement-amended sand (Normal stress = 10 psi).**

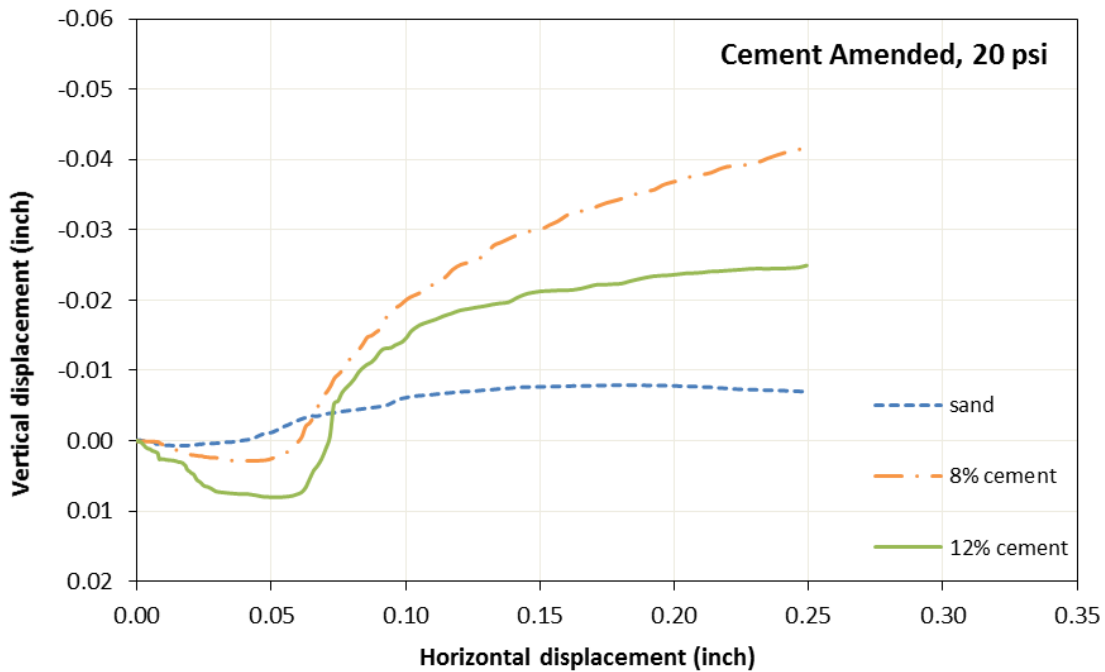


**Figure 46. Vertical displacement versus horizontal displacement for cement-amended sand (Normal stress = 10 psi).**

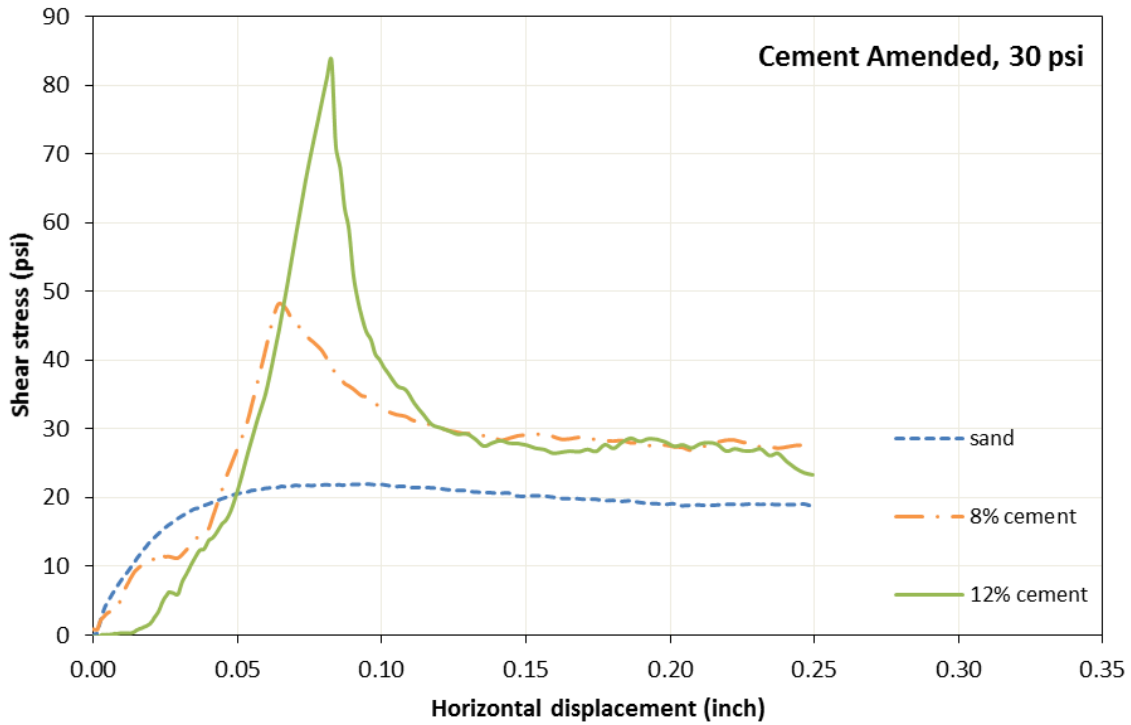




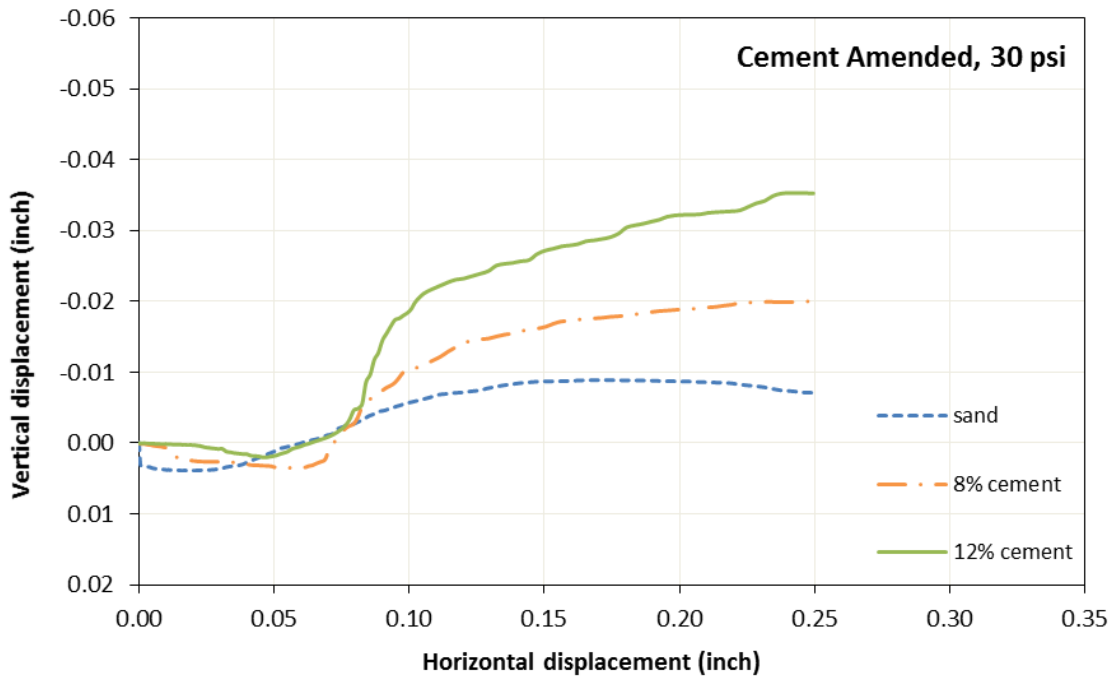
**Figure 47. Shear stress versus horizontal displacement for cement-amended sand (Normal stress = 20 psi).**



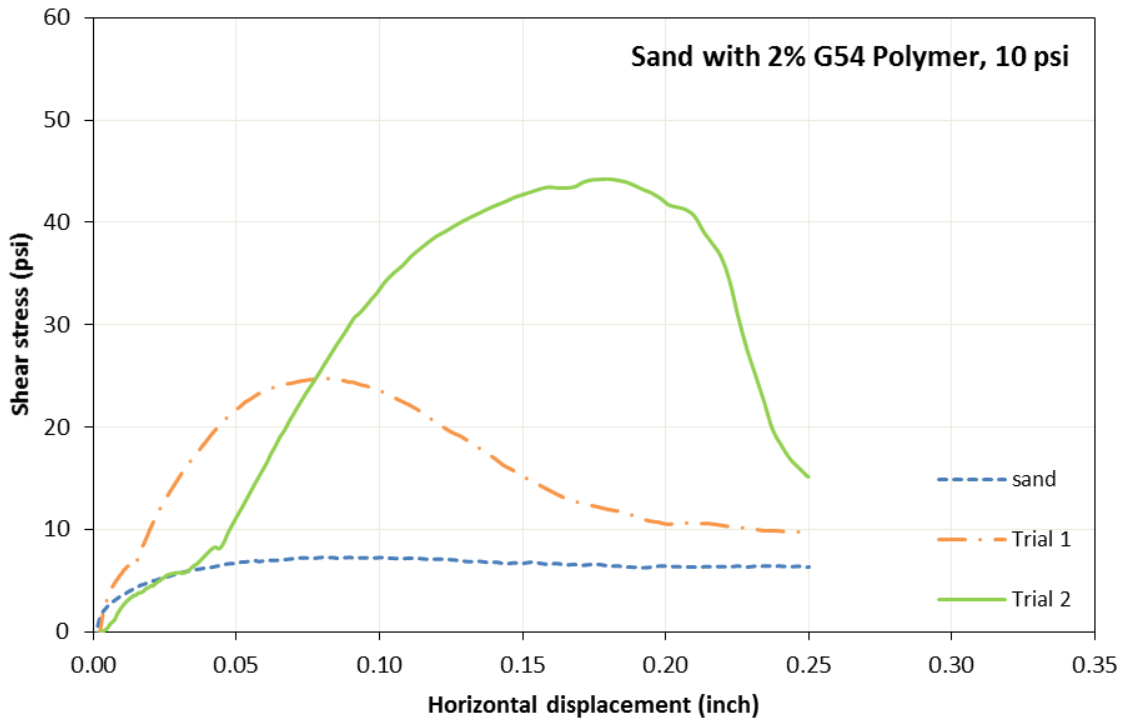
**Figure 48. Vertical displacement versus horizontal displacement for cement-amended sand (Normal stress = 20 psi).**



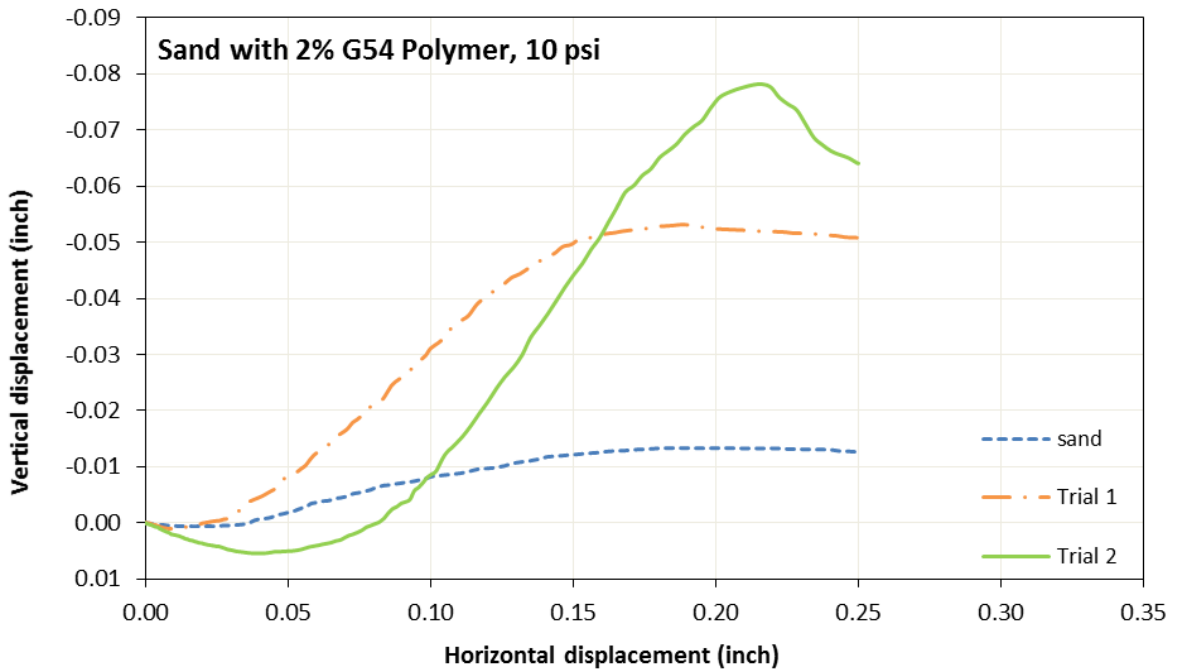
**Figure 49. Shear stress versus horizontal displacement for cement-amended sand (Normal stress = 30 psi).**



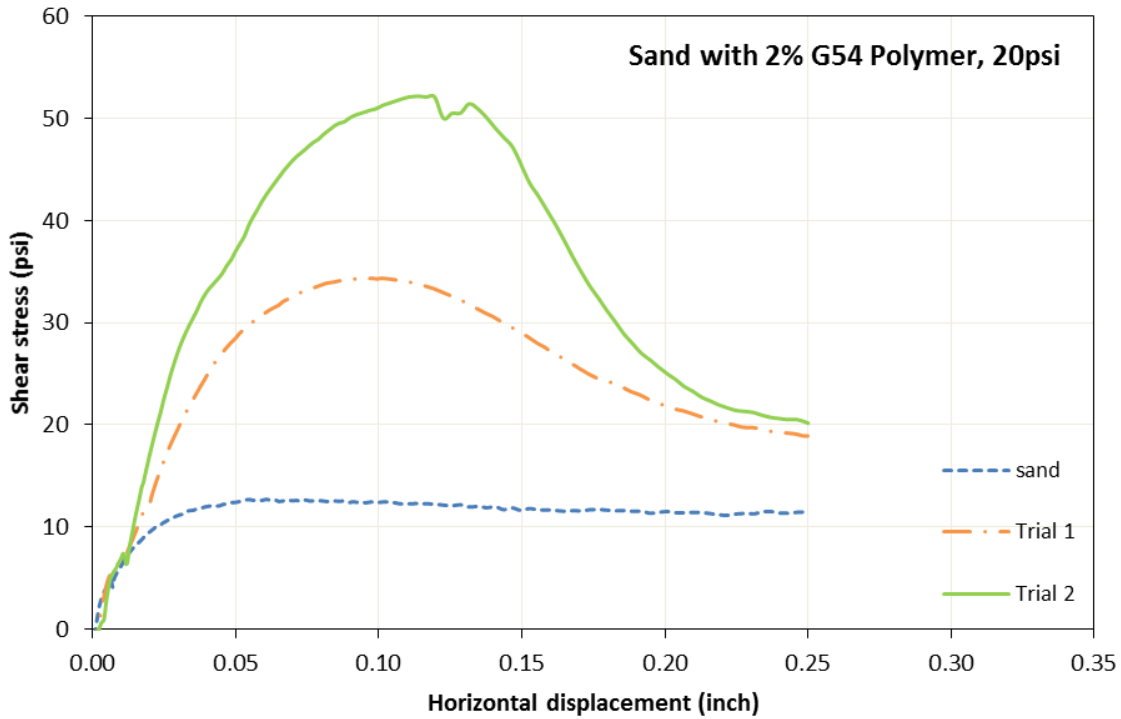
**Figure 50. Vertical displacement versus horizontal displacement for cement-amended sand (Normal stress = 30 psi).**



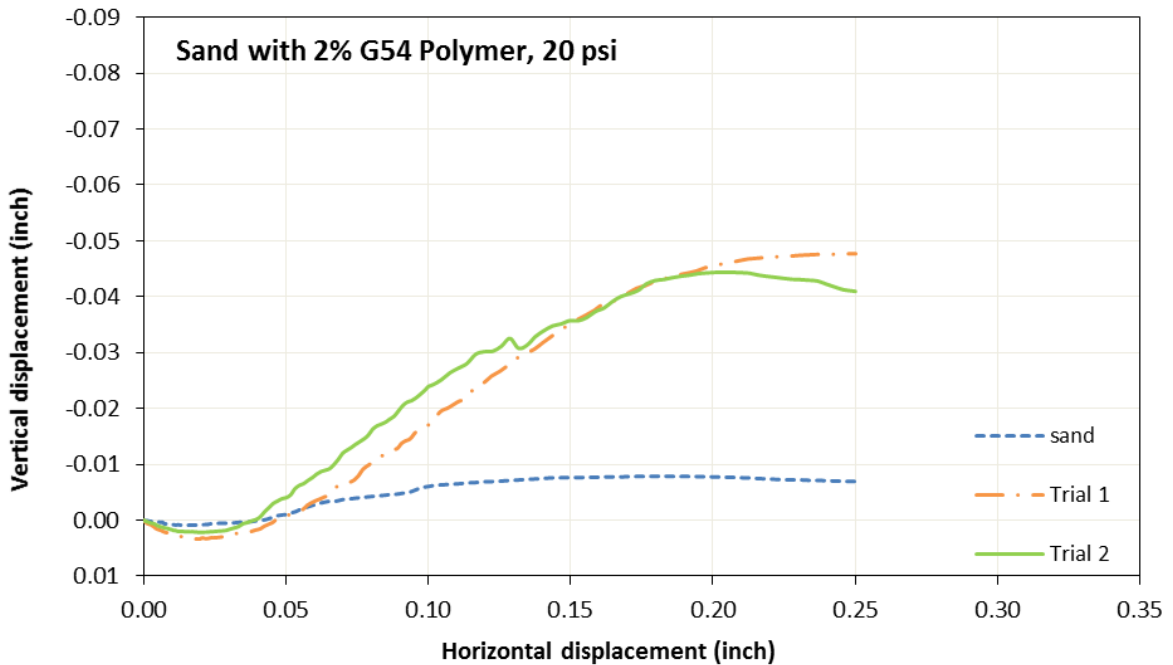
**Figure 51. Shear stress versus horizontal displacement for G54 polymer-amended sand (Normal stress = 10 psi).**



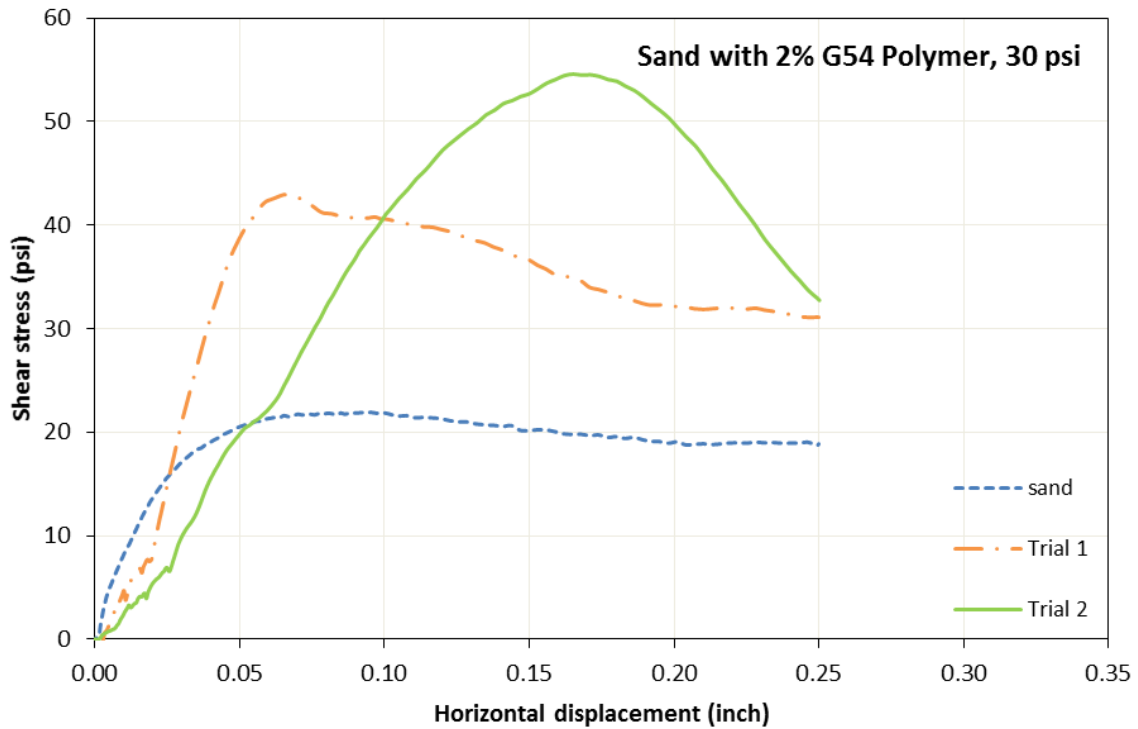
**Figure 52. Vertical displacement versus horizontal displacement for G54 polymer-amended sand (Normal stress = 10 psi).**



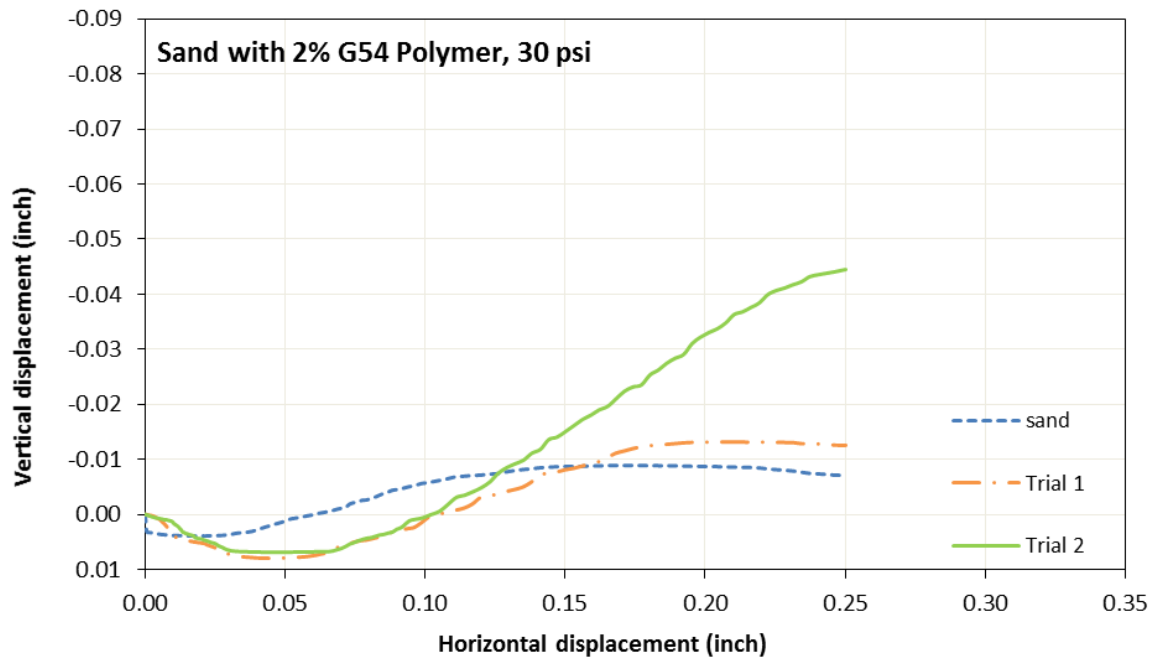
**Figure 53. Shear stress versus horizontal displacement for G54 polymer-amended sand (Normal stress = 20 psi).**



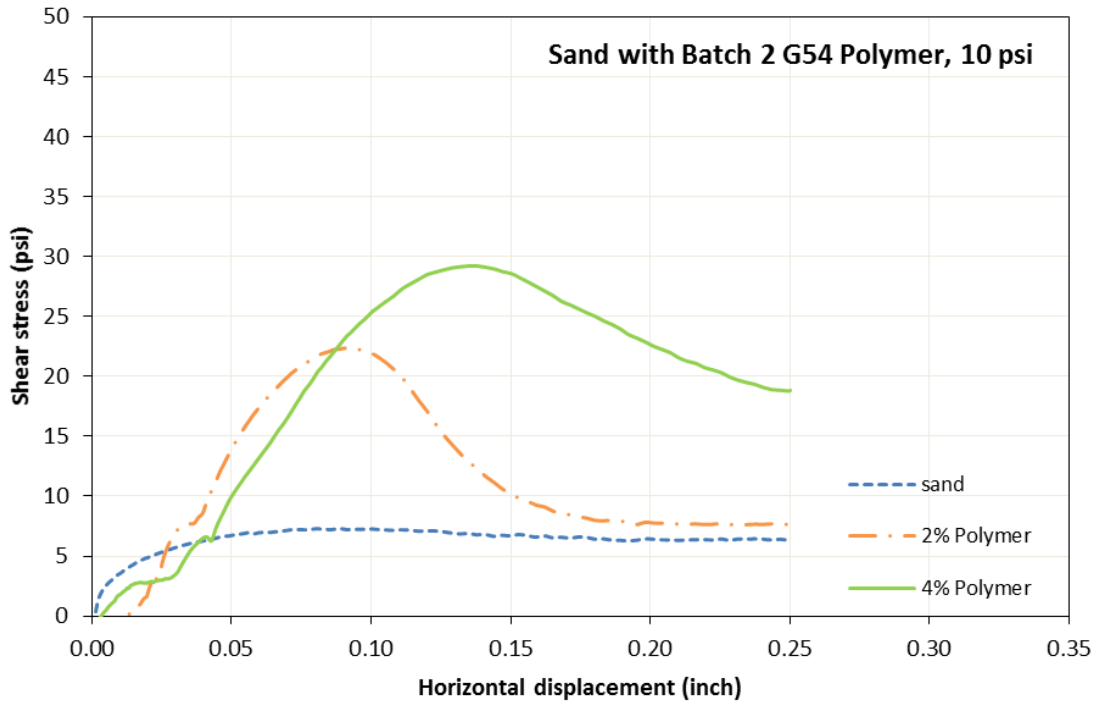
**Figure 54. Vertical displacement versus horizontal displacement for G54 polymer-amended sand (Normal stress = 20 psi).**



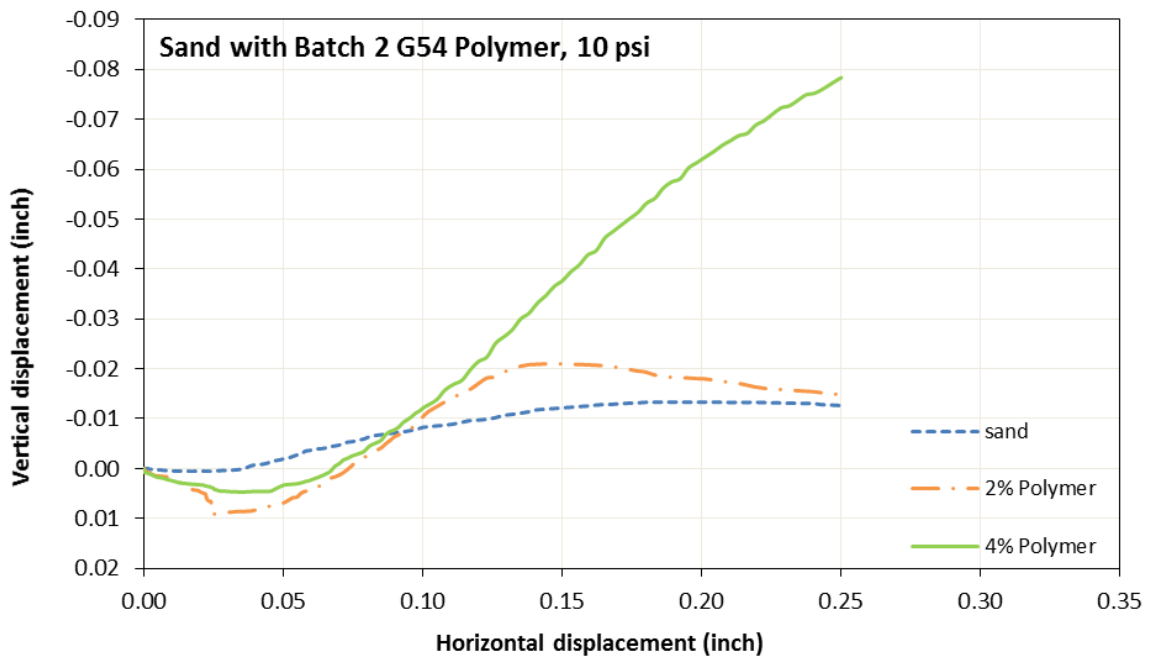
**Figure 55. Shear stress versus horizontal displacement for G54 polymer-amended sand (Normal stress = 30 psi).**



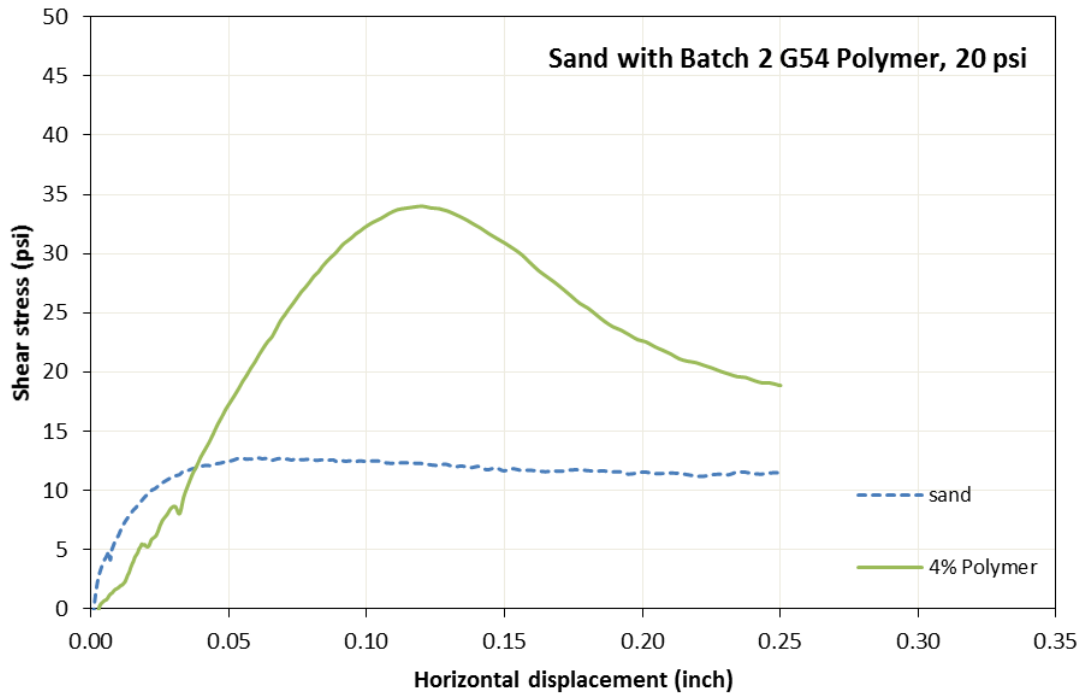
**Figure 56. Vertical displacement versus horizontal displacement for G54 polymer-amended sand (Normal stress = 30 psi).**



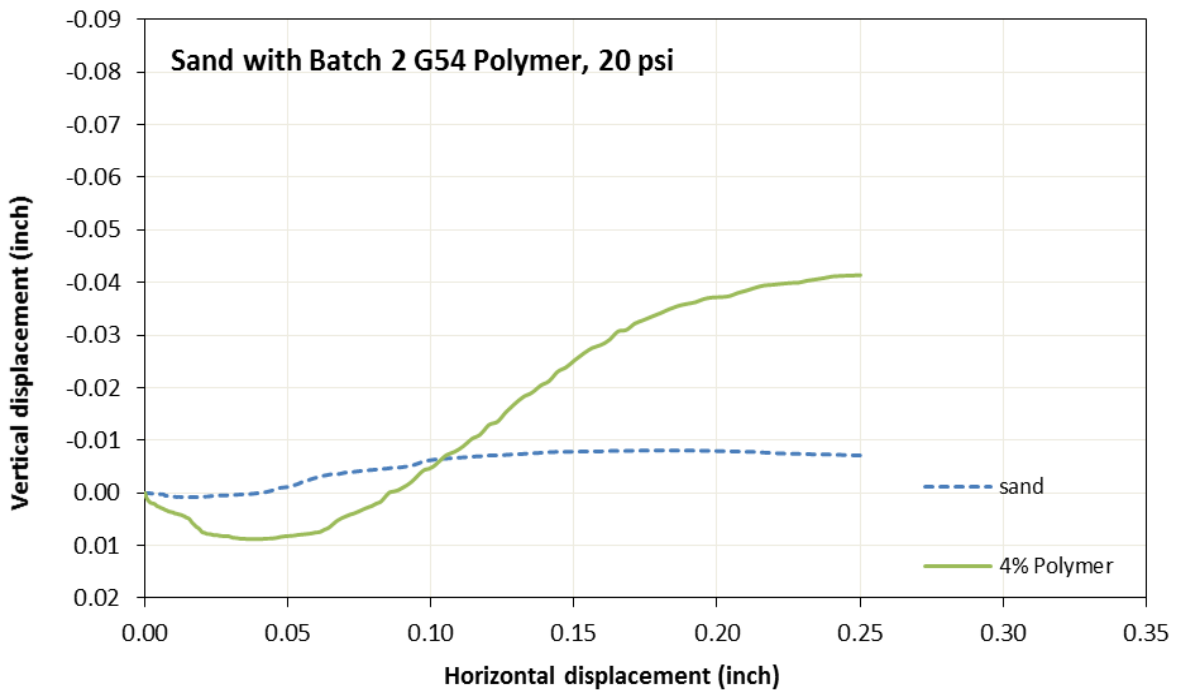
**Figure 57. Shear stress versus horizontal displacement for Batch 2 G54 polymer-amended sand (Normal stress = 10 psi).**



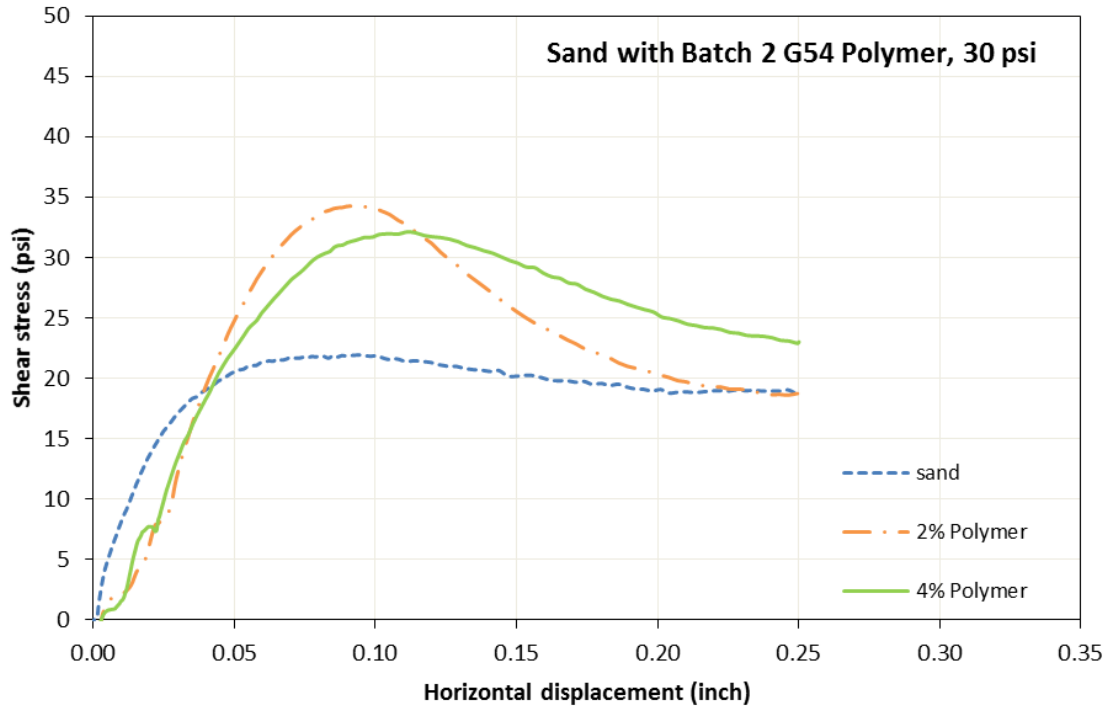
**Figure 58. Vertical displacement versus horizontal displacement for Batch G54 polymer-amended sand (Normal stress = 10 psi).**



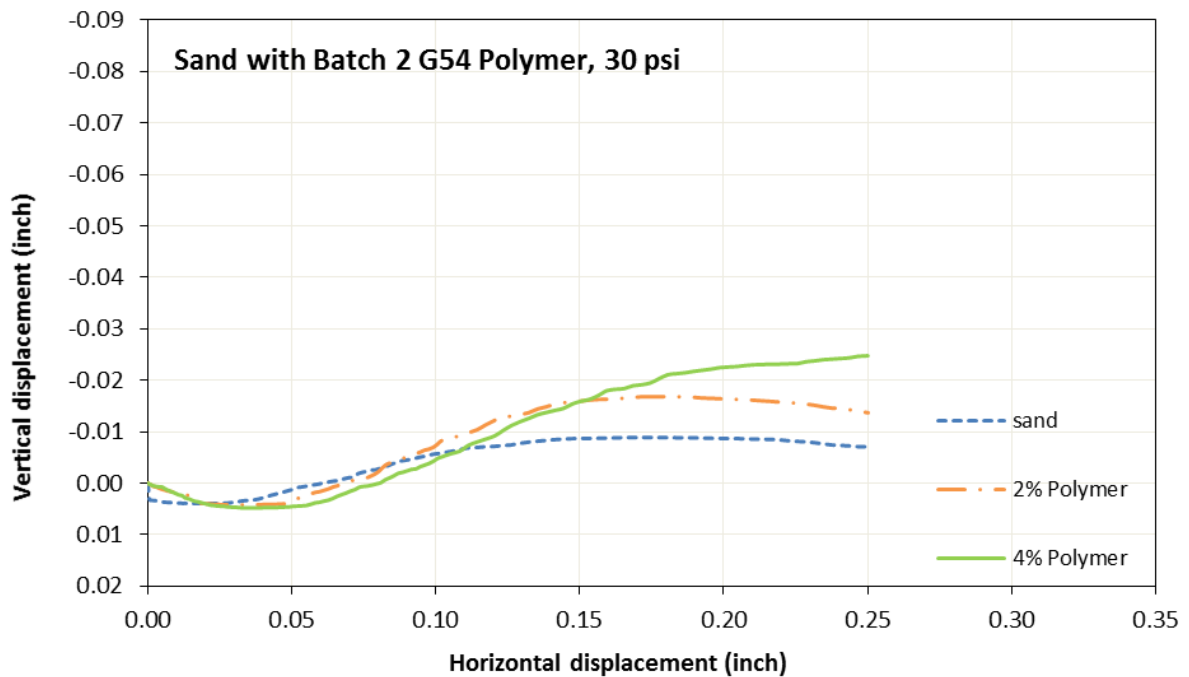
**Figure 59. Shear stress versus horizontal displacement for Batch 2 G54 polymer-amended sand (Normal stress = 20 psi).**



**Figure 60. Vertical displacement versus horizontal displacement for Batch G54 polymer-amended sand (Normal stress = 20 psi).**



**Figure 61. Shear stress versus horizontal displacement for Batch 2 G54 polymer-amended sand (Normal stress = 30 psi).**



**Figure 62. Vertical displacement versus horizontal displacement for Batch G54 polymer-amended sand (Normal stress = 30 psi).**



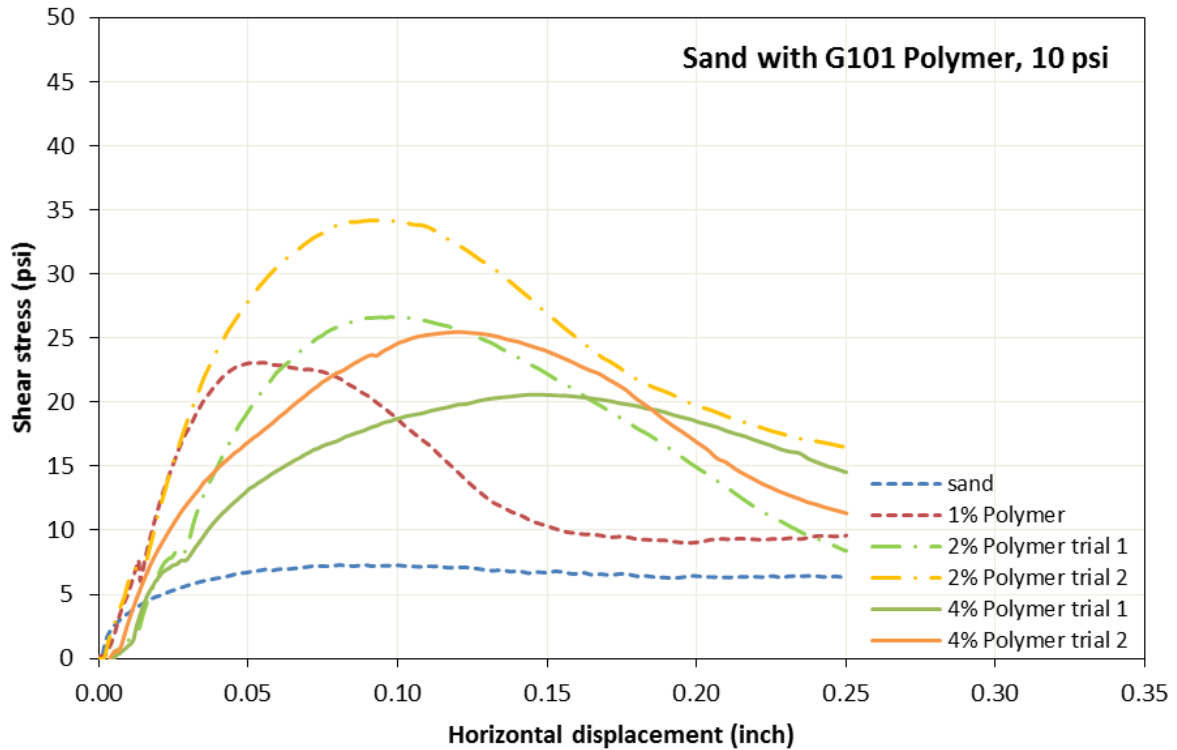


Figure 63. Shear stress versus horizontal displacement for G101 polymer-amended sand (Normal stress = 10 psi).

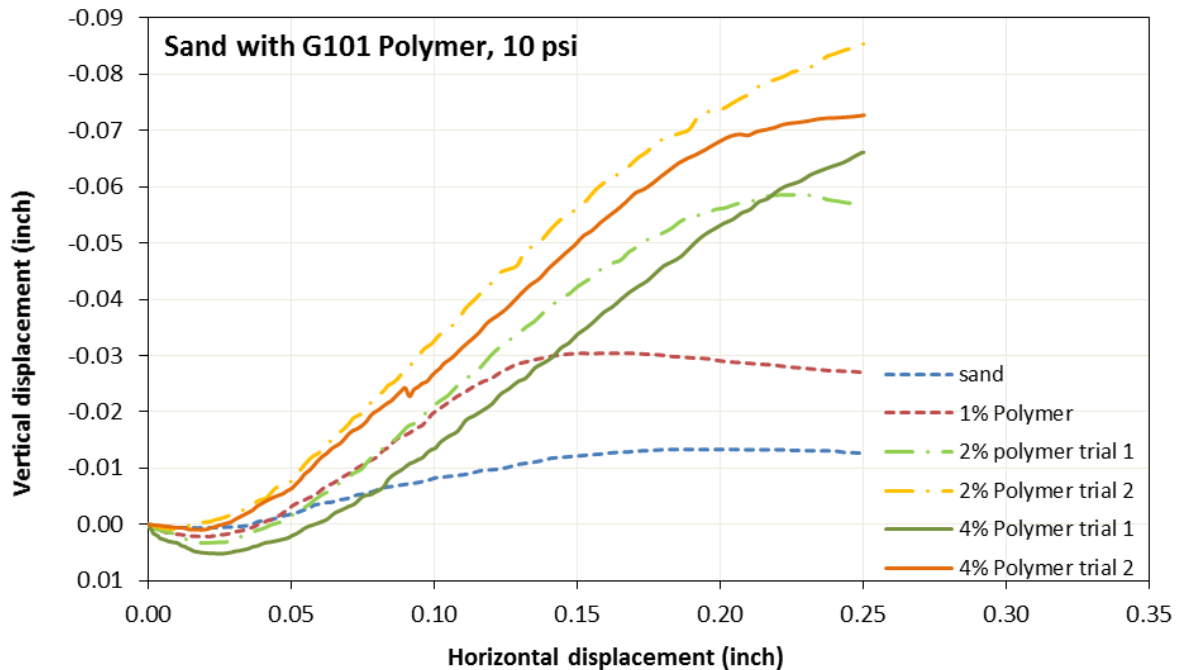


Figure 64. Vertical displacement versus horizontal displacement for G101 polymer-amended sand. (Normal stress = 10 psi).

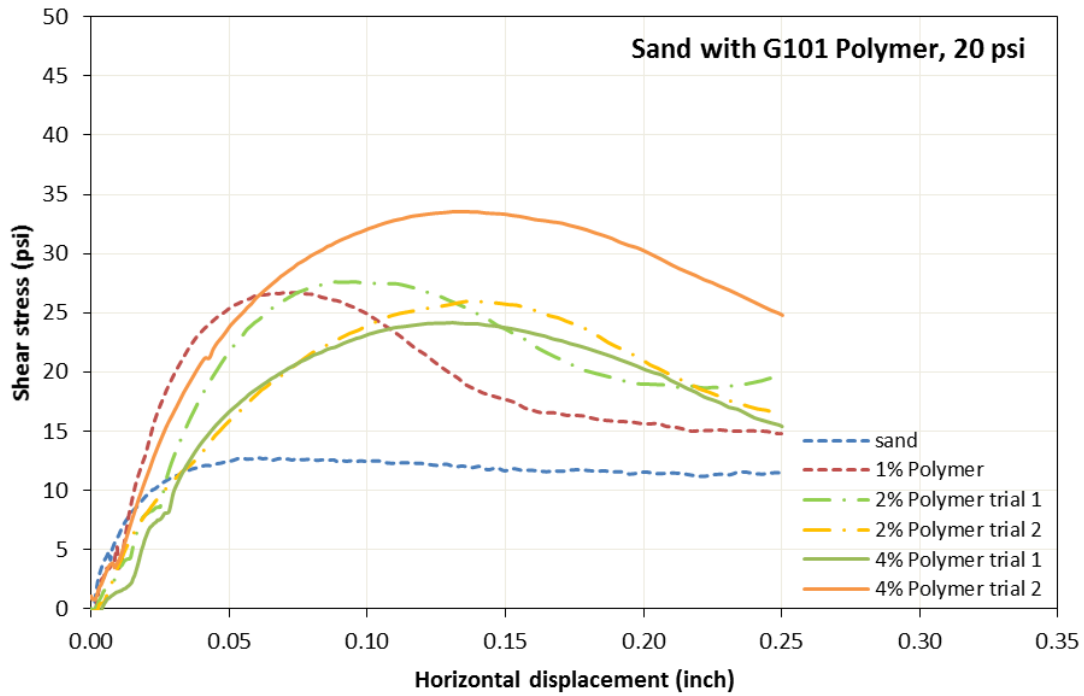


Figure 65. Shear stress versus horizontal displacement for G101 polymer-amended sand (Normal stress = 20 psi).

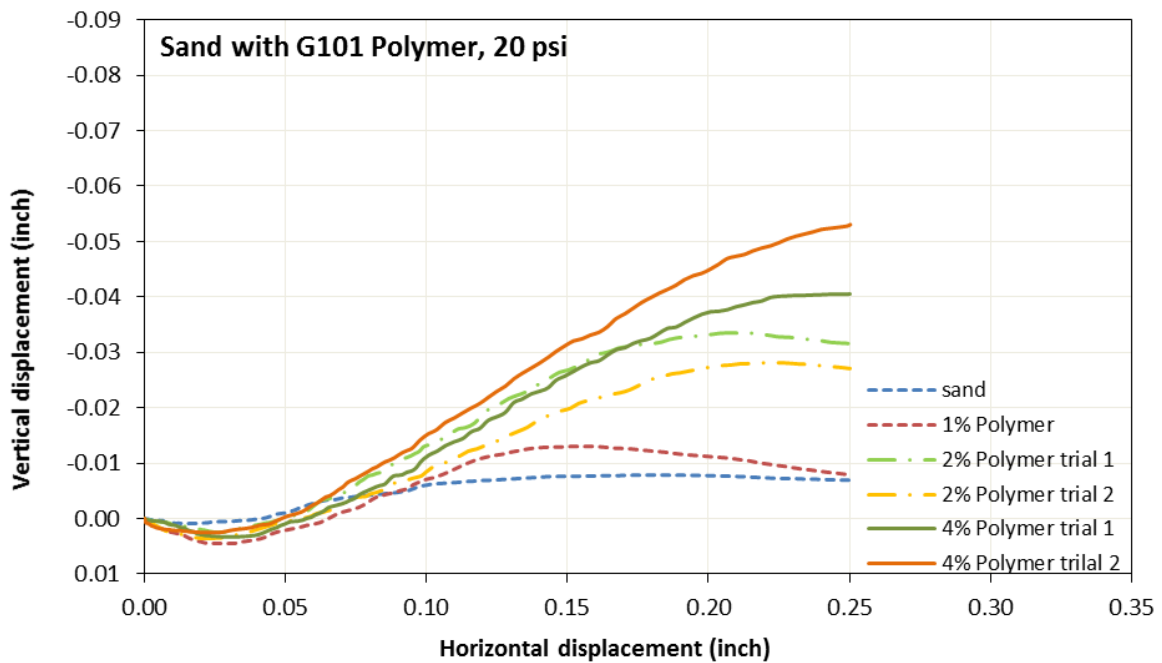


Figure 66. Vertical displacement versus horizontal displacement for G101 polymer-amended sand (Normal stress = 20 psi).

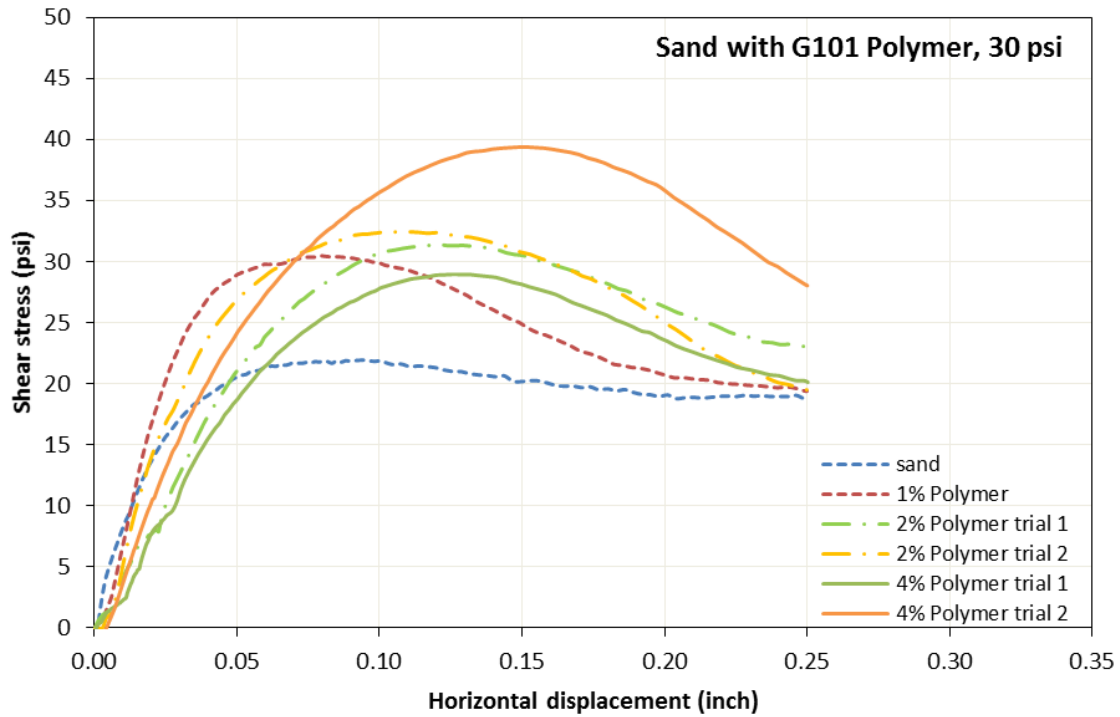


Figure 67. Shear stress versus horizontal displacement for G101 polymer-amended sand (Normal stress = 30 psi).

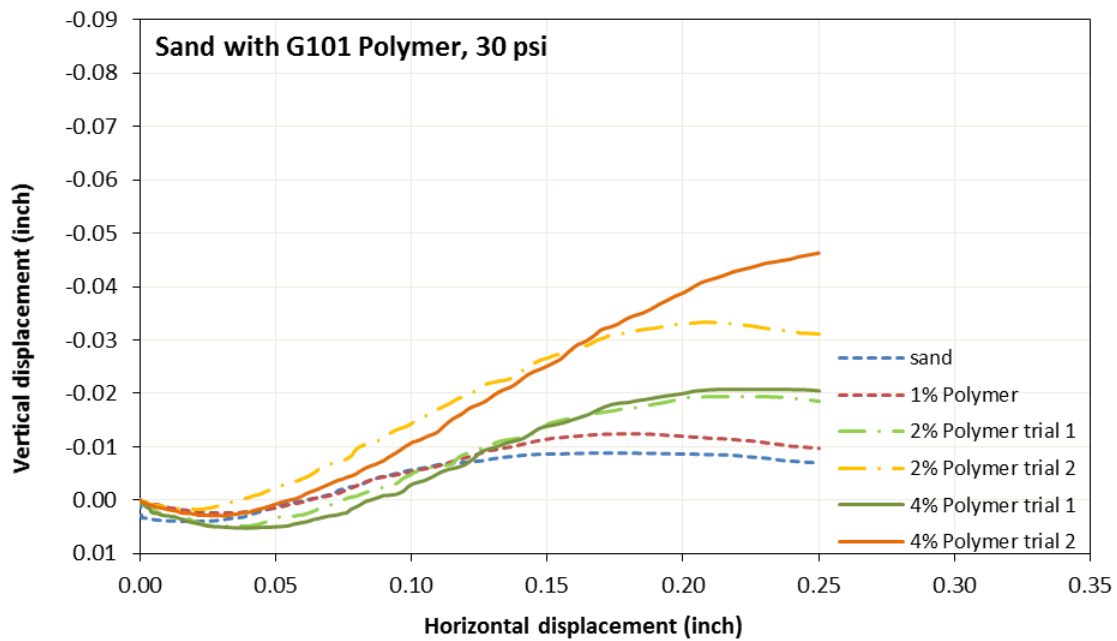


Figure 68. Vertical displacement versus horizontal displacement for G101 polymer-amended sand (Normal stress = 30 psi).

Drained Mohr-Coulomb shear strength parameters from direct shear tests

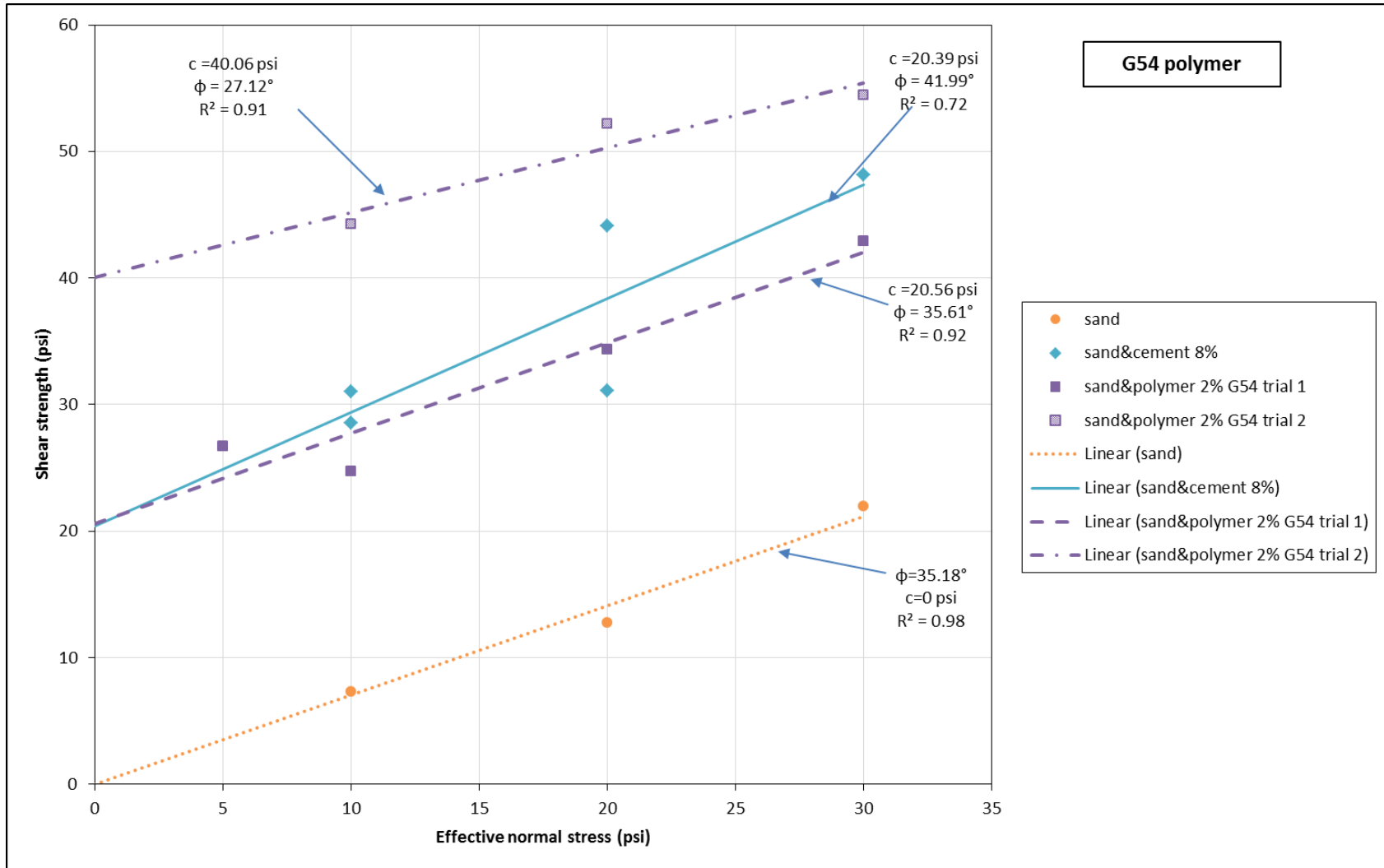
As discussed in the previous section, the polymer-amended sand exhibited peak shear stresses that were greater than the untreated sand, and similar to those of the 8% cement-amended sand. The peak shear stresses are plotted against normal stress in Figures 69 through 71, from which the Mohr-Coulomb failure parameters (cohesion and friction angle) were determined. The cohesion, friction angle, and  $R^2$  values from linear regression of all DS tests are shown in the plots and also summarized in Table 10. In the table, Trial 1 and Trial 2 refer to tests on two independent sets of samples which were performed to examine the repeatability of results.

As shown in Figure 69 and Table 10, the friction angles of the polymer-amended sands were generally less than or equal to that of the untreated sand ( $35.2^\circ$ ). The friction angles of cement-amended sand were larger than that of the untreated sand, especially for a cement content of 12%.

The polymer-stabilized sand exhibited significant cohesion ranging between 13 and 40 psi, which was similar to the cohesion of the cement-stabilized sand (i.e., 20 and 37 psi for cement contents of 8% and 12%, respectively). However, there was no clear trend between polymer content and cohesion or friction angle, as demonstrated in Figures 72 and 73. This may be partially due to the variations in material properties that were clearly evident between the G54, G101 and Batch 2 G54 polymers provided to the research team. Due to the lack of a clear trend, it was not feasible to develop an empirical model to predict the relationships between polymer content and shear strength parameters of amended soil, and further study is needed to examine this possibility.

**Table 10. Summary of shear strength parameters from direct shear tests on Ottawa 20/30 sand specimens.**

Test Series		Days between trail 1 and trail 2	Peak Shear Stress (psi)			Internal Angle of Friction (deg)	Cohesion (psi)	R <sup>2</sup>	
			Normal Stress = 10 psi	Normal Stress =20 psi	Normal Stress = 30 psi				
Sand		-	7.3	12.8	22.0	35.2	0.0	0.98	
Cement	8%	-	29.8	37.6	39.6	42.0	20.4	0.72	
	12%	-	52.5	67.8	83.6	57.3	36.8	0.98	
G54 Polymer	2%	Trial 1	14	24.8	34.4	42.9	35.6	20.6	0.92
		Trial 2		44.2	52.2	54.5	27.1	40.1	0.92
G101 Polymer	1%		-	23.1	26.7	30.5	20.3	19.3	0.99
	2%	Trial 1	17	26.6	27.6	31.4	15.1	23.9	0.85
		Trial 2		34.1	25.9	32.4	33.0	13.0	1
	4%	Trial 1	21	20.6	24.2	29.0	22.7	16.2	0.99
Trial 2		25.5		33.5	39.4	35.8	18.9	0.85	
Batch 2 G54 Polymer	2%		-	22.3	-	34.3	30.9	16.4	1
	4%		-	29.2	34.0	32.1	8.3	28.8	0.36



**Figure 69. Shear strength versus effective normal stress and Mohr-Coulomb failure envelopes for G54 polymer.**

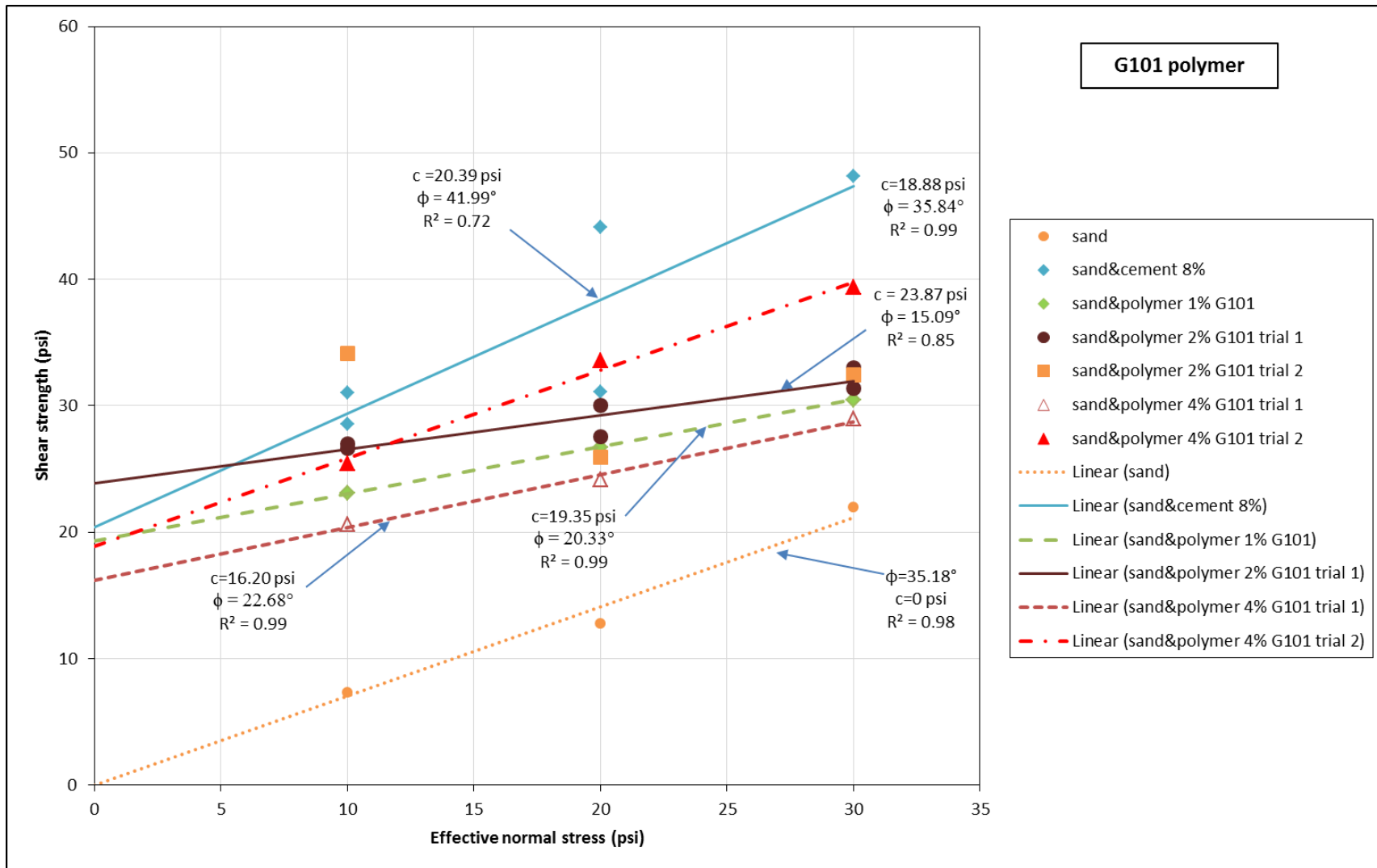


Figure 70. Shear strength versus effective normal stress and Mohr-Coulomb failure envelopes for G101 polymer.

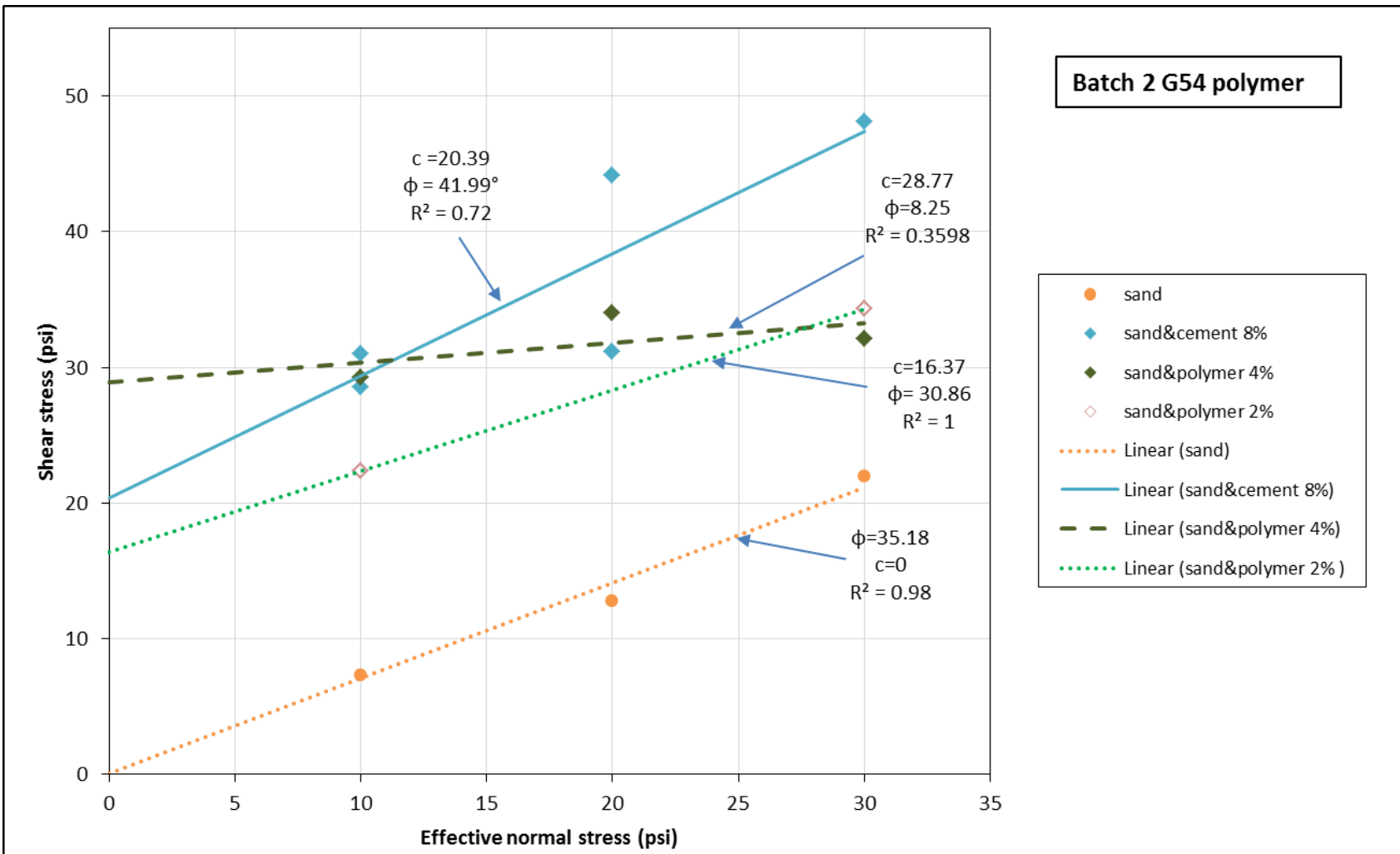


Figure 71. Shear strength versus effective normal stress and Mohr-Coulomb failure envelopes for batch 2 G54 polymer.



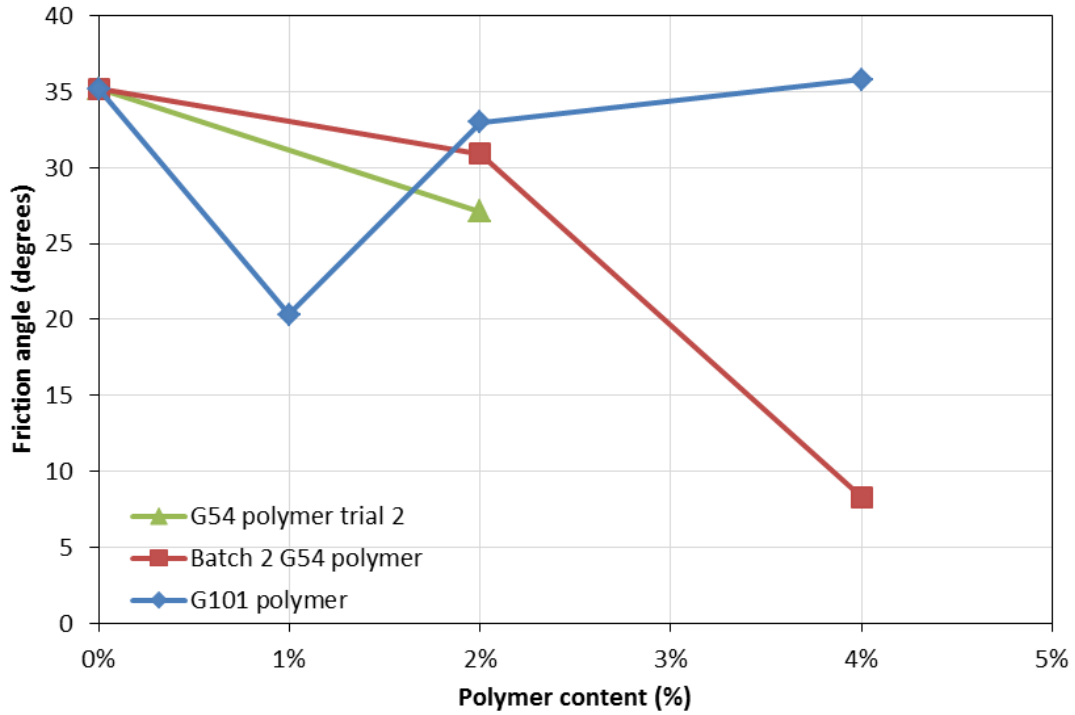


Figure 72. Relationship between friction angle and polymer content.

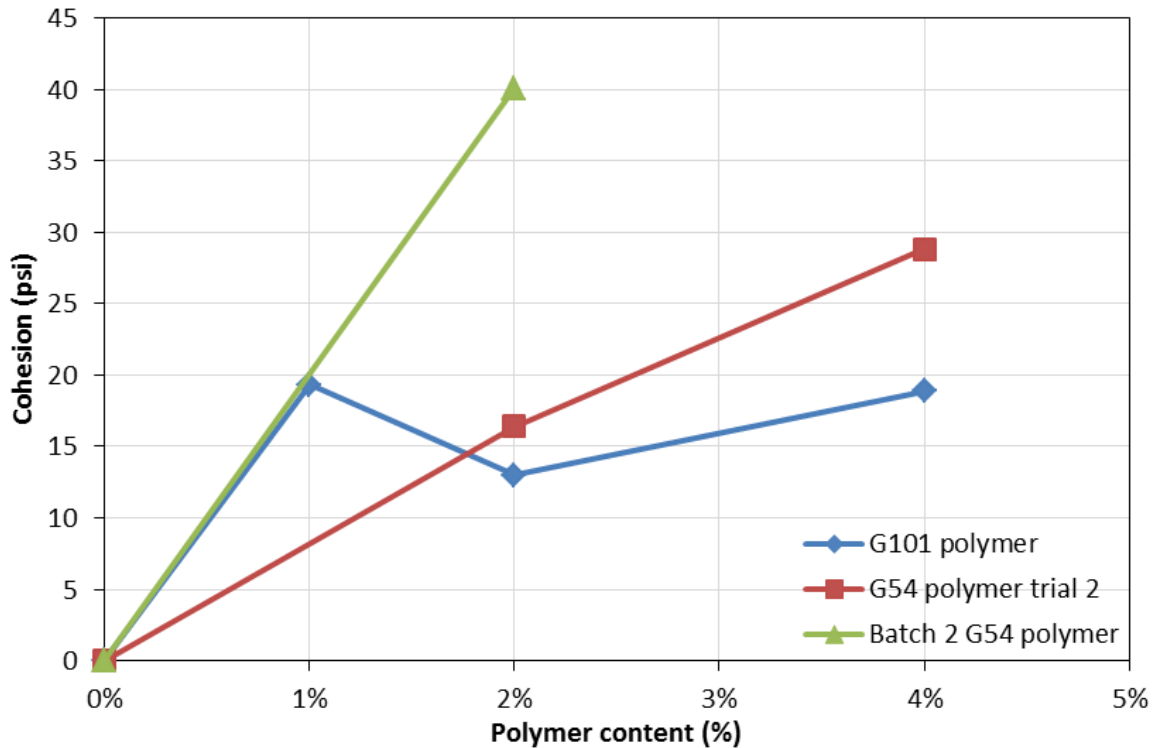
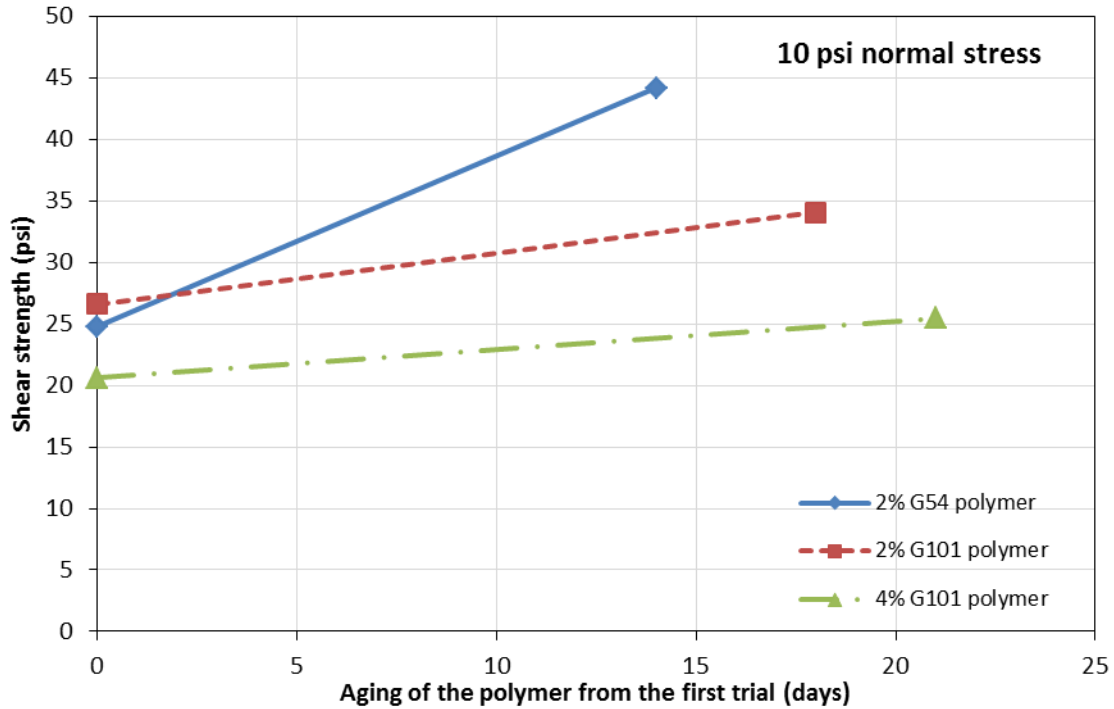


Figure 73. Relationship between cohesion and polymer content.

*Effect of polymer aging on shear stress*

From Table 10, it can be observed from the tests with multiple trials that there is a relationship between shear stress and polymer aging. The peak shear strengths at 10 psi normal stress for various polymers and polymer contents are shown in Figure 74 as a function of the time of testing from Trial 1. The polymer material was stored in a freezer and thawed at room temperature for one hour before preparing the specimens for the first trials. The polymer was then placed back into the freezer and stored until specimens for the second trials were prepared. At the time of DS testing, the polymer and soil had been in contact for approximately the same period of time after mixing the specimens, so the only different aging variable was the length of time that the polymer had been stored in the freezer prior to Trial 1 compared to Trial 2. All the polymer ages in Figure 74 are measured from the time of the first trial on each specimen, and indicate that peak shear stress increases with polymer age. For 2% and 4% G101 polymer, the slope of the two lines are similar because both of the first trials were conducted at approximately the same time and the same material was used.

These results indicate that the shear strength of polymer-amended specimens can increase with age of the polymer due to changing of polymer properties with time. At the time of the first direct shear test trials, the polymer-amended soil was more easily sheared. With age, either the strength of the polymer itself increased, or else the polymer was able to more effectively bond to the soil particles.



**Figure 74. Relationship between shear strength and age of the polymer from date of Trial 1.**

#### Healing property of polymer-amended specimens

During the tests, an interesting phenomenon was observed; the broken polymer-amended sample would sometimes heal by itself, as shown in Figure 75. This behavior was observed several times, and it occurred whenever the polymer content was 4%. The cross-linking potential or tensile strength of the polymer may explain this phenomenon. For a 4% polymer content, the specimen was not broken into two parts, so there was no sand loss, and the polymer re-bonded the top and bottom halves of the specimen after 7 days at room temperature. The shear strengths of the healed specimens were not as large as those of the original samples, but still represented an improvement over the untreated sand (Figures 76 through 79).



**Figure 75. Healed 4% polymer-amended sand specimen 7 days after first DS test.**

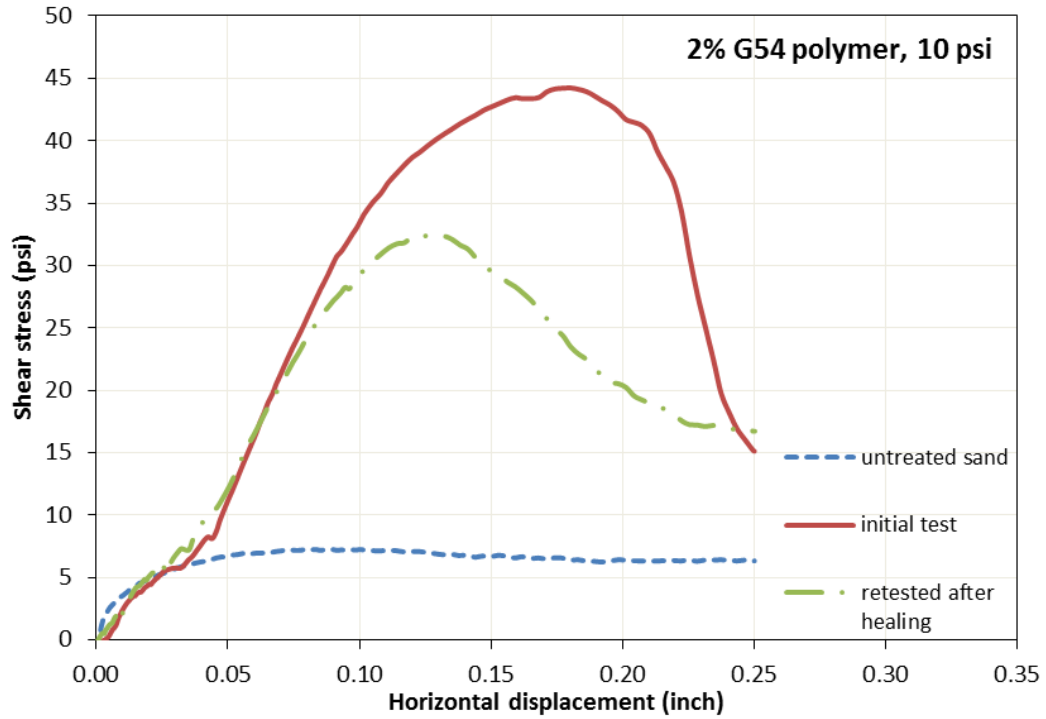


Figure 76. Shear stress versus horizontal displacement for untreated sand, initial test on polymer-treated sand, and retest after 7 days healing (Normal stress = 10 psi).

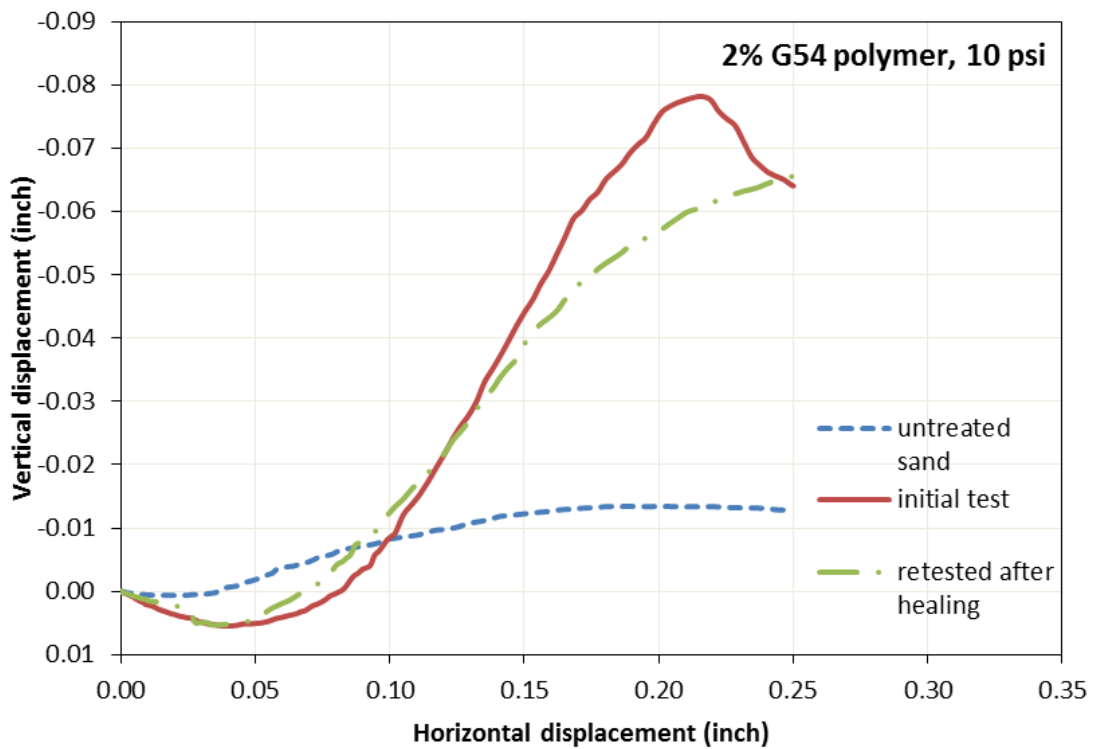


Figure 77. Vertical displacement versus horizontal displacement for untreated sand, initial test on polymer-treated sand, and retest after 7 days healing (Normal stress = 10 psi).

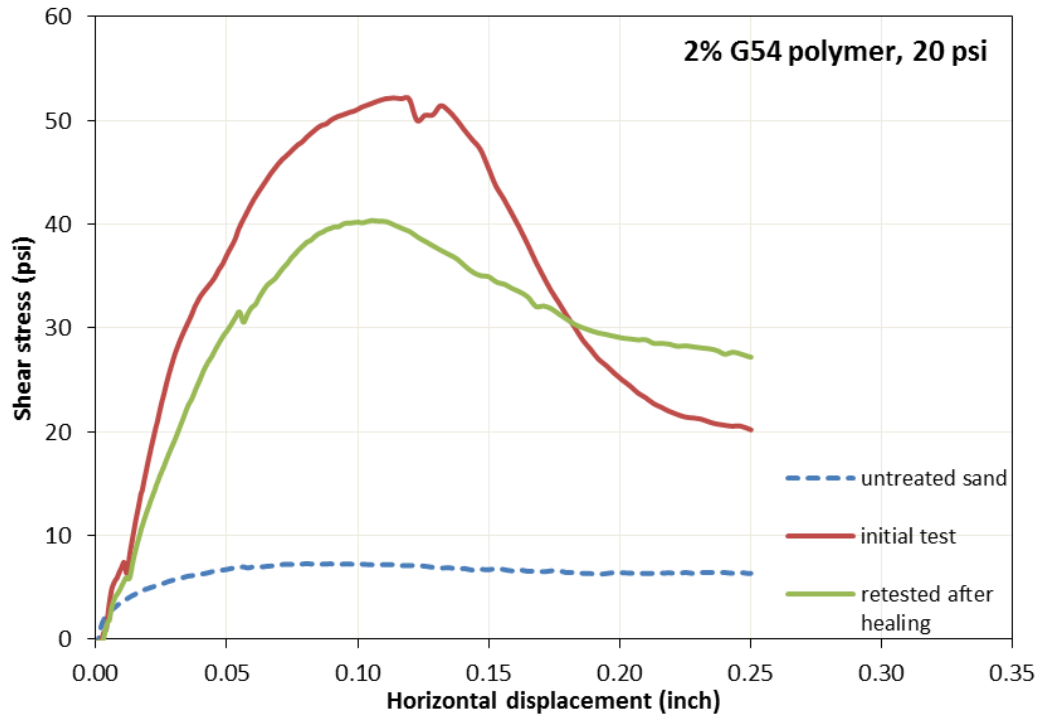


Figure 78. Shear stress versus horizontal displacement for untreated sand, initial test on polymer-treated sand, and retest after 7 days healing (Normal stress = 20 psi).

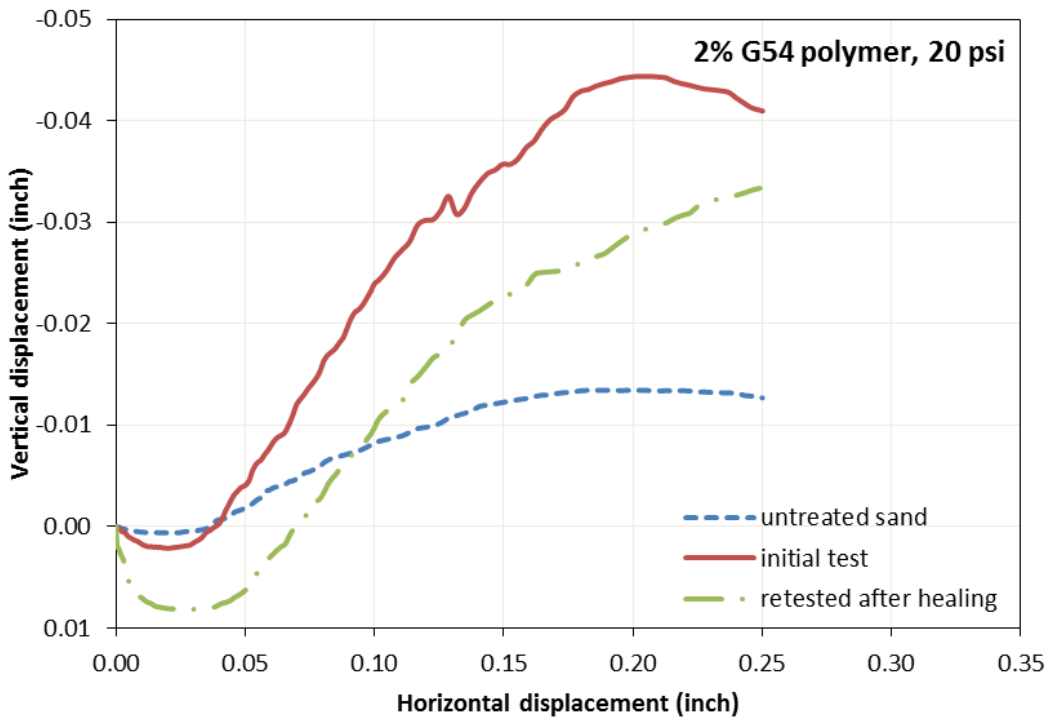


Figure 79. Vertical displacement versus horizontal displacement for untreated sand, initial test on polymer-treated sand, and retest after 7 days healing (Normal stress = 20 psi).

*Effect of water on polymer-amended specimens*

To examine the potential performance of the biopolymers for stabilization of soils, it is important to note that actual soil sites will exist under various states of saturation due to subsurface flow, surface infiltration, and fluctuation of the ground-water table. Therefore, a few specimens treated with G101 polymer were submerged in water for several days after DS tests. The specimens were found to lose most of their cohesion when submerged (Figure 80). To address this problem, it may be possible to treat the polymers with acetic acid during the pyrolysis process, which will impart a degree of water-resistance. Testing of dry and saturated specimens treated with such water-resistant polymers is beyond the scope of the present study and is recommended for further research.



**Figure 80. Submerged polymer-amended specimens. The specimen on the left was gently probed with a spatula.**

## CHAPTER 5. CONCLUSIONS AND RECOMMENDATIONS

This chapter summarizes the test results and significant findings regarding the shear strength of amended Western Iowa loess and Ottawa sand. Compaction test results, unconfined compression test results, and direct shear results are included. Recommendations for future research are also provided based on the findings from this study.

### Conclusions

#### Unconfined compression test results for loess

Unconfined compression tests were conducted on untreated loess specimens compacted at OMC and OMC–2%, and loess specimens with 2% to 4% monomer content compacted at OMC. The influence of curing time and monomer content on the strength and stress-strain behavior was investigated for stabilized and untreated loess specimens. Conclusions from these tests are as follows:

- The unconfined compressive strength increased with curing time for all specimens. For a 7-day curing time, the unconfined compressive strength of the untreated specimens increased more rapidly than for the monomer-amended specimens. For curing times longer than 7 days, the unconfined compressive strength of stabilized loess increased faster than that of untreated loess.
- The unconfined compressive strength decreased significantly with an increase of monomer content for a 7-day curing time. The lowest UCS, a decrease of nearly one-half, occurred at 4% added monomer. However, after a curing time of 28 days, the UCS of 2% monomer-stabilized loess was higher than that of the untreated sample



(at OMC=2%) for two out of three trials. The monomer thus shows the potential to improve the strength of loess with additional curing time.

- The stiffness of the samples generally decreased with increasing monomer content, and the stress-strain behavior initially showed a slight decrease in ductility at 1 and 7 hours, but eventually showed an increase in ductility after a curing time of 28 days.

### **Direct shear test results for Ottawa sand**

Direct shear tests were conducted on untreated, cement-stabilized, and three types of polymer-stabilized Ottawa sand specimens to determine their shear strengths. The shear strength was found to be sensitive to both the polymer content and polymer age. The improvement of shear-strength behavior and other significant findings were as follows:

- The shear strength of the polymer-amended sand was increased compared to untreated sand. For the same normal stress level, the peak shear stress was increased by 1.5 to 2 times for the polymer-stabilized specimens, resulting in shear stresses similar to those of 8% cement-stabilized sand specimens. The G54 polymer produced the best results, with peak shear stresses roughly 1.5 times those of an 8% cement sample. Cohesion was increased from 0 psi to a range of 13 to 40 psi by adding polymer, significantly improving its shear-strength behavior of the sand. The friction angle of polymer-amended sand was similar to or lower than untreated sand.
- The dilation of the polymer-amended sand was significantly increased, as determined from the vertical displacement measurements, and the failure behavior also changed from brittle to ductile. The increased dilation might improve liquefaction resistance by reducing positive excess pore pressures during cyclic shearing, and possibly

creating negative pore pressures which would increase the effective stress and thus further increase the cyclic shear-stress resistance.

- Polymer properties directly influenced the shear strength of amended sand. Higher shear strength was measured for the sands stabilized with G54 polymer, which itself was qualitatively observed to have a greater viscosity and strength than the G101 and Batch 2 G54 polymers. Increasing age of the polymer was also observed to increase its viscosity and strength, resulting in an even more significant increase in the measured shear strength of the polymer-stabilized sand with time.
- The healing property of the polymer was demonstrated in several polymer-amended samples, i.e., the tested sample self-repaired back toward its initial stabilized state. The shear strength of the healed samples was still greater than that of untreated sand.

### Summary

This study evaluated the effects of biopolymer and monomer stabilization on the shear strength and stress-strain behavior of loess and sand. For monomer-amended loess, the unconfined compressive strength was significantly lower after 7-days curing, and decreased with increasing monomer content compared to untreated specimens, but increased after 28-days curing. The shear strength of biopolymer-amended sand was significantly increased by addition of the polymer. Polymer stabilization increased the shear strength of the sand comparable to that of 8% cement-stabilized sand, and also provided a healing potential. The biopolymer used in this study thus may provide a more sustainable alternative to traditional stabilization methods while offering environmental and economic benefits.

### **Recommendations for further research**

The evaluation of the biopolymer stabilization for shear strength of soil was conducted using three types of laboratory tests in this study (compaction, unconfined compression, and direct shear). Additional laboratory studies are needed to further study the behavior of polymer-amended soils to determine the optimum polymer content and stabilization process for various types of soils and polymers. The beneficial effects of polymer aging should be studied further by performing a more comprehensive set of tests at curing times of 28 days and beyond. Rheological tests on the polymer itself should also be performed to characterize its viscosity and shear strength as a function of the different polymer blends and polymer age. Statistical modeling using equations or graphs should be developed to predict the effects of various concentrations and types of polymer on soil strength. Additionally, computational multi-physics modeling should be performed using a finite element analysis of the coupled mechanical and chemical phenomena, to generate predictive models for a wider range of soil types and proposed biopolymer types.

The reaction of soil and polymer can be observed through microscopic methodologies to determine possible mechanisms of bonding for a given polymer and the resulting strength of amended soil. The waterproofing abilities of various polymers should also be examined by testing the static strength of dry and saturated polymer-amended samples. Then, cyclic triaxial or cyclic simple shear tests with pore pressure measurement should be performed to evaluate the potential of the bio-polymers for improving liquefaction resistance of sands and silts.

Additional applications and soil types could be examined, such as freeze/thaw behavior, or stabilization of clays in terms of shear strength, reduction of consolidation settlements, and improvement in shrink/swell behavior.

It is also recommended to conduct economic analyses to assess the performance of biopolymers relative to traditional stabilization methods in terms of a cost/benefit ratio, and sustainability analyses to examine the relative benefits of polymer stabilization traditional stabilizers such as cement and fly-ash, in terms of the potential savings of finite natural resources and reduction of greenhouse gasses.

Finally, the performance and field-implementation of biopolymer stabilization should be investigated further by conducting field research studies.

## WORKS CITED

- Al-Khanbashi, A., & Abdalla, S. W. (2006). Evaluation of three waterborne polymers as stabilizers for sandy soil. *Geotechnical & Geological Engineering*, 24(6), 1603-1625.
- Angelova, R. N. (2007). Loess-Cement long term strength - a facilitating factor for loess improvement applications". *Geologica Balcania*, 21-24.
- ASTM. (2007). Standard Specification for Portland Cement. In *Annual book of ASTM standards* (Vol. ASTM C150). West Conshohocken, PA.
- ASTM. (2007). Standard Test Method for Direct Shear Test of Soils under Consolidated Drained Conditions. In *Annual book of ASTM standards* (Vol. ASTM D3080). West Conshohocken, PA.
- ASTM. (2007). Standard Test Methods for Compressive Strength of Molded Soil-Cement Cylinders. In *Annual book of ASTM standards* (Vol. ASTM D1633). West Conshohocken, PA.
- ASTM. (2007). Standard Test Methods for Laboratory Compaction Characteristics of Soil. In *Annual book of ASTM standards* (Vol. ASTM D698). West Conshohocken, PA.
- ASTM. (2007). Standard Test Methods for Laboratory Compaction Characteristics of Soil. In *Annual book of ASTM standards* (Vol. ASTM D1557). West Conshohocken, PA.
- ASTM. (2007). Standard Test Methods for Maximum Index Density and Unit Weight of Soils Using a Vibratory Table. In *Annual book of ASTM standards* (Vol. ASTM D4253). West Conshohocken, PA.
- ASTM. (2007). Standard Test Methods for Minimum Index Density and Unit Weight of Soils and Calculation of Relative Density. West Conshohocken, PA.
- ASTM. (2007). Standard Test Methods for Unconfined Compressive Strength of Cohesive Soil. In *Annual book of ASTM standards* (Vol. ASTM D2166). West Conshohocken, PA.
- Barden, L., & Sides, G. R. (n.d.). Engineering behavior and structure of compacted clay. 96, 1171.
- Bjerrum, L., Casagrande, A., Peck, R. B., & Skempton, A. W. (1960). *From Theory to Practice in soil mechanics, selections from the writings of Karl Terzaghi*. New York, N.Y.: John Wiley and Sons, Inc.
- Chu, T. Y., & Davidson, D. T. (1966). *Some laboratory tests for the evaluation of stabilized soils*. Progress Report.

- CMI. (1985). *A practical guide to soil stabilization & reclamation techniques*. Oklahoma: CMI corporation.
- Craig, R. F. (2005). *Craig's soil mechanics*. London and New York: Taylor & Francis e-Library.
- Das, B. M. (2010). *Principles of geotechnical engineering*. Stamford: Gengage Learning.
- DeJong, J. T., & Michael, B. F. (2006). Microbially Induced Cementation to Control Sand Response to Undrained Shear. *Journal of Geotechnical and Geoenvironmental Engineering*, 132(11), pp. 1381-1392.
- DeJong, J. T., Mortensen, M. B., Martinez, C. B., & Nelson, D. C. (2010). Bio-mediated soil improvement. *Ecological Engineering*, 36(2), pp. 197-210.
- Eden, D., & Furkert, R. (1988). Loess, its distribution, geology and soils. *Proceedings of an International Symposium on Loess*.
- El Howayek, A., Huang, P.-T., Bisnett, R., & Santagata, M. C. (2011). *Identification and Behavior of Collapsible Soils*. Joint Transportation Research Program.
- Forrester, M. (2014). *Personal communication*.
- Gibbs, H., & Holland, W. (1960). Petrographic and Engineering Properties of Loess. *Engineering Monograph No. 28*, 37.
- Great Britain, D. o. (1952). *Soil mechanics for road engineeris*. London: Her Majesty's Stationery Office.
- Hans, W. F., & Sibel, P. (1991). Soil stabilization and grouting. In H. Y. Fang, *Foundation engineering handbook 2nd edition* (pp. 317-378). New York.
- Hernandez, N., Williams, R. C., & Cochran, W. E. (2014). The battle for the "green" polymer. Different approaches for biopolymer synthesis: bioadvantaged vs. bioreplacement. *12*.
- Hilf, J. W. (1956). *An investigation of Pore-water pressure in compacted cohesive soils*. Colorado: Department of the interior.
- Hilf, J. W. (1991). Compacted Fill. In *Foundation engineering handbook* (pp. 249-316). Springer US.
- Hogentogler, C. A. (1936). Essentials of soil compaction. In *Proceedings of hte highway research board* (pp. 309-316). Washington.

- Holtz, D. R., Kovacs, D. W., & Sheahan, C. T. (2011). *An introduction to geotechnical engineering*. Upper Saddle River: Pearson Education, Inc.
- Homauoni , Z. J., & Yasrobi, S. S. (2011). Stabilization of dune sand with poly (methyl methacrylate) and polyvinyl acetate using dry and wet processing. *Geotechnical and Geological Engineering*, 29(4), pp. 571-579.
- Homauoni, Z. J., & Seyed, S. Y. (2011). Stabilization of dune sand with poly (methyl methacrylate) and polyvinyl acetate using dry and wet processing. *Geotechnical and Geological Engineering*, 29(4), pp. 571-579.
- Ivanov, V., & Chu, J. (2008). Applications of microorganisms to geotechnical engineering for bioclogging and biocementation of soil in situ. *Reviews in Environmental Science and Bio/Technology*, 7(2), pp. 139-153.
- Karol, R. H. (2003). Biostabilization. In *Chemical Grouting and soil stabilization, third edition*. New Brunswick.
- Lambe, T. W. (1960). Structure of compacted clay. *Transactions ASCE*, 125, pp. 682-705.
- Li, C. (2013). Using the Iowa K test and the gyratory compaction test to improve the Compaction Forecasting Expert Database. Ames.
- Naeini, S. A., Naderinia , B., & Lzadi, E. (2012). Unconfined compressive strength of clayey soils stabilized with waterborne polymer. *KSCE Journal of Civil Engineering*, 16(6), 943-949.
- Newman, K., & Tingle, J. S. (2004). Emulsion polymers for soil stabilization. *Worldwide Airport Transfer Conference*. New Jersey, USA.
- Oflaherty, C. A., Edgar, C. E., & Davidson, D. T. (1963). The Iowa State Compaction Apparatus: A small sample apparatus for use in obtaining density and strength measurements of soils and soil-additives. *42nd Highway Research Board Meeting*.
- O'Flaherty, C. A., Edgar, C. E., & Davidson, D. T. (1963). *The Iowa State compaction apparatus: a small smple apparatus for use in obraining density and strength measurements of soils and soil-additives*. Washington: Iowa Engineering Experiment.
- Olson, R. E. (1963). Effectives stress theory of soil compaction. 89, 27-45.
- Orts, W. J., Roa-Espinosa, A., & Sojka, R. E. (2007). Use of synthetic polymers and biopolymers for soil stabilization in agricultural, construction, and military applications. *Journal of Materials in Civil Engineering*, 19(1).

- PCA. (1956). Short-cut test procedures for sandy soils. In P. c. association, *Soil-cement Laboratory Handbook*. Chicago.
- Portland Cement Association. (1971). short-cut test procedures for sandy soils. In *Soil-cement laboratory handbook* (pp. 38-42). Portland Cement Association.
- Proctor, R. R. (1933). Fundamental Principles of soil compaction. In A. W. Marr, *A history of progresses*.
- Rahman, W., Freer-Hewish, R., & Ghataora, G. S. (2008). investigation into the use of cement stabilized sand in road pavement construction in Bangladesh. *Airfield and Highway Pavements*, 434-441.
- Santamarina, J. C., & Gye, C. C. (2001). Determination of critical state parameters in sandy soils-simple procedure. *Geotechnical testing journal*, 24.2, 185-192.
- Sirichai, H., & Watcharin, G. (2010). The Stabilization of Loess by Chemical Additives of Road Base. *EJGE*, 15, 1651-1668.
- Terzaghi, K. (1925). *Erdbaumechanik auf bodenphysikalischer grundlage*. Leipzig u. Wien, F. Deuticke .
- Tingle , J. S., & Stanton, R. L. (2003). Stabilization of clay soils with nontraditional additives. *Transportation Research Record: Journal of the Transportation Research Board*, 1819(1), 72-84.
- Tingle, J. S., Newman, J. K., & Larson, S. L. (2007). Stabilization Mechanisms of Nontraditional Additives. *Transportation Research Record: Journal of the Transportation Research Board*, 1989(1), 59-67.
- USGS. (1999, July). *Geology of the Loess Hills, Iowa*. Retrieved from <http://pubs.usgs.gov/info/loess/>
- Williams, C. R., Cascione , A. A., Cochran, W. E., & Hernandez, B. N. (2014). *Development of Bio-based polymers for use in asphalt*. Iowa State University.
- Wilson, S. D. (1950). Small soil compaction apparatus duplicates field results closely. *Engineering News-Record*, 145(18), 34-36.